

Gender queer & NC - ICCS employees

No. of responses = 5



Survey Results

Legend

Question text

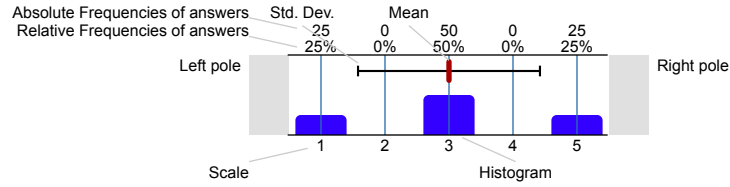

n=No. of responses
 av.=Mean
 dev.=Std. Dev.
 ab.=Abstention

2. Employee Info

2.1) Primary Employment Classification:

Faculty, Full-Time Teaching	<input type="text" value="2"/>	40%	n=5
Faculty, Full-Time Non-Teaching (Counselors, Librarians)	<input type="text" value="0"/>	0%	
Faculty, Adjunct Teaching	<input type="text" value="0"/>	0%	
Faculty, Adjunct Non-Teaching (Counselors, Librarians)	<input type="text" value="0"/>	0%	
Classified, Full-Time Permanent	<input type="text" value="2"/>	40%	
Classified, Part-Time Permanent	<input type="text" value="0"/>	0%	
Supervisor	<input type="text" value="0"/>	0%	
Administrator	<input type="text" value="1"/>	20%	

2.2) Years worked at ARC (any location):

less than 1 year	<input type="text" value="0"/>	0%	n=5
1 to 4 years	<input type="text" value="3"/>	60%	
5 to 9 years	<input type="text" value="2"/>	40%	
10 to 14 years	<input type="text" value="0"/>	0%	
15 to 19 years	<input type="text" value="0"/>	0%	
20 years or more	<input type="text" value="0"/>	0%	

2.3) Primary work location at ARC:

ARC Main Campus	<input type="text" value="5"/>	100%	n=5
Natomas Center	<input type="text" value="0"/>	0%	
McClellan Center	<input type="text" value="0"/>	0%	
Mather Center	<input type="text" value="0"/>	0%	

3. Demographics

3.1) What is your gender identity? (MARK ALL THAT APPLY)

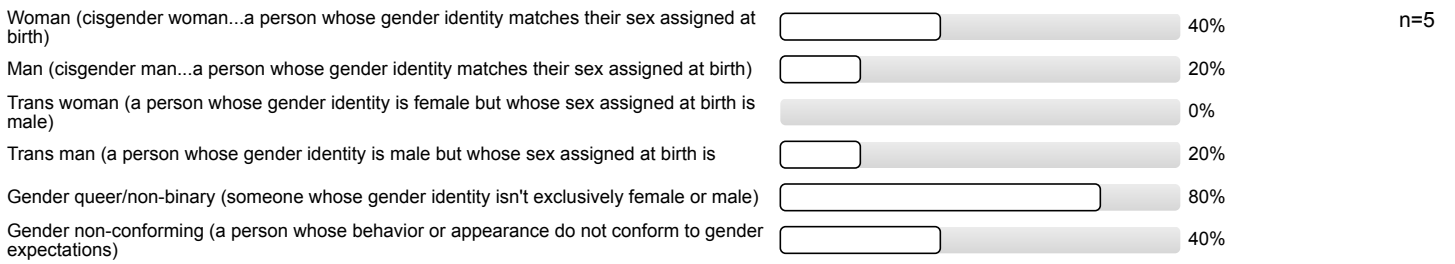

3.3) What is your sexual orientation? (MARK ALL THAT APPLY)

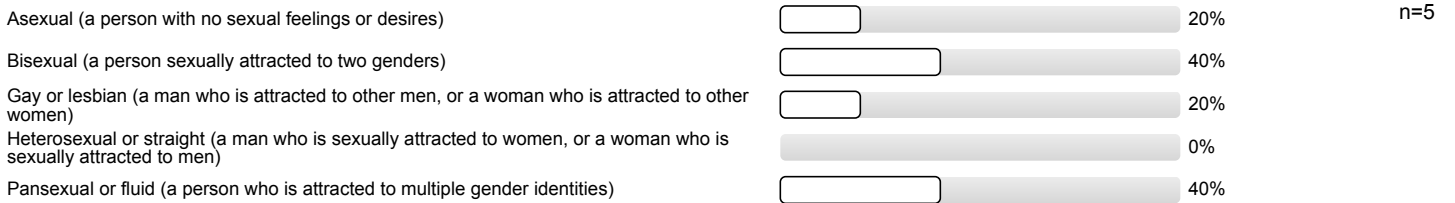

3.5) What is your age (in years)?

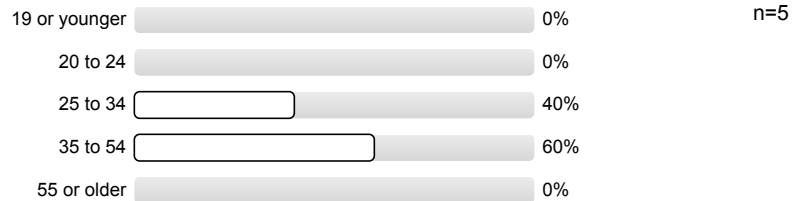

3.6) What is your race/ethnicity? (MARK ALL THAT APPLY)

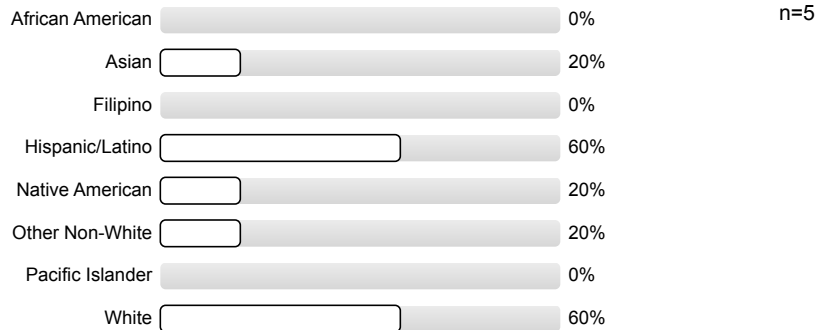

3.8) With which religions, worldviews, or spiritual backgrounds do you identify? (MARK ALL THAT APPLY)

n=5

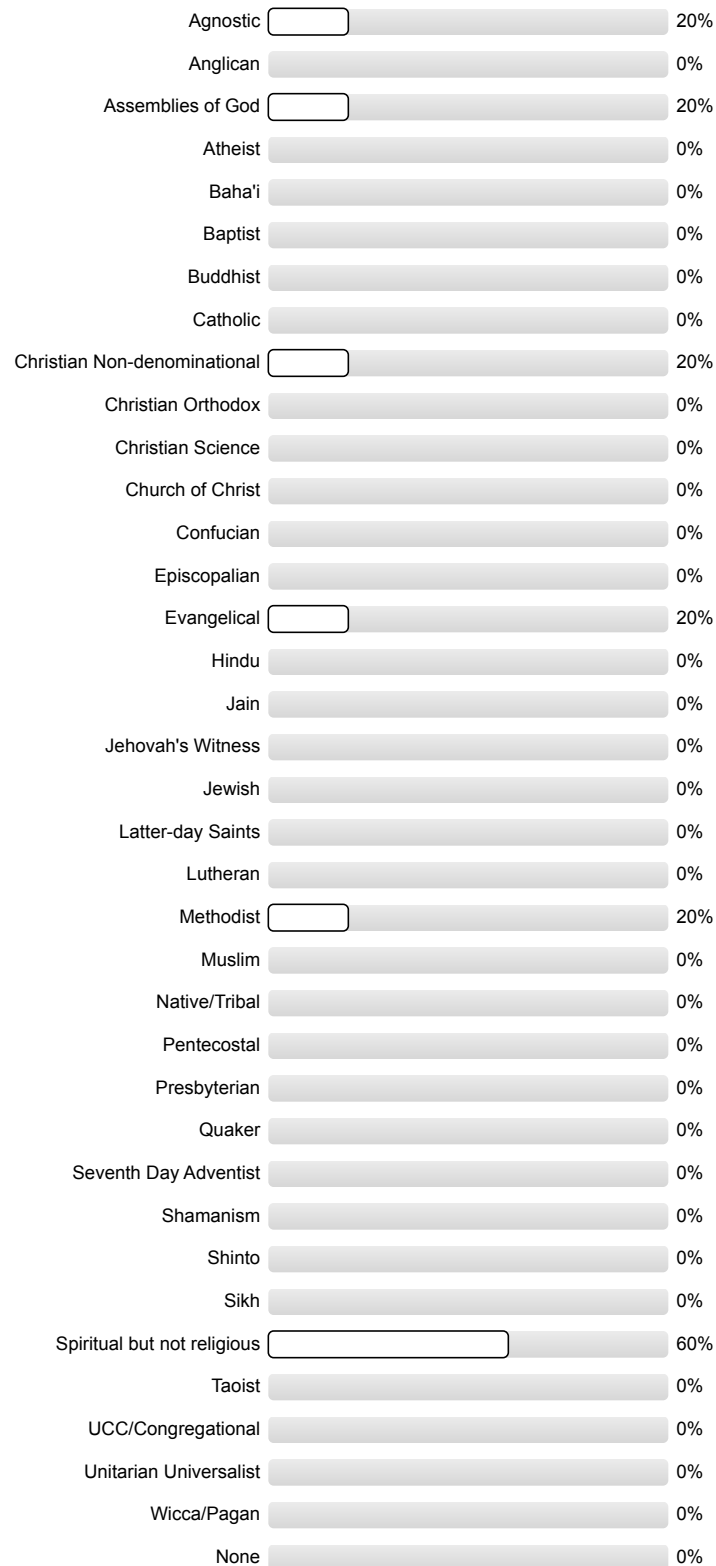

3.10) With which **one** religion, worldview or spiritual background do you **most strongly** identify? (MARK ONLY **ONE**)



3.12) What is your highest level of education?

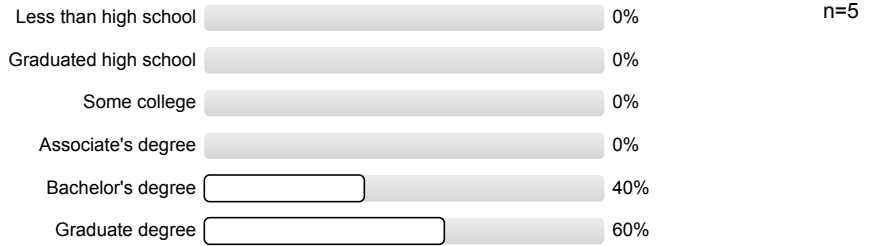

3.13) Do you have any of the following types of disabilities? (MARK ALL THAT APPLY)

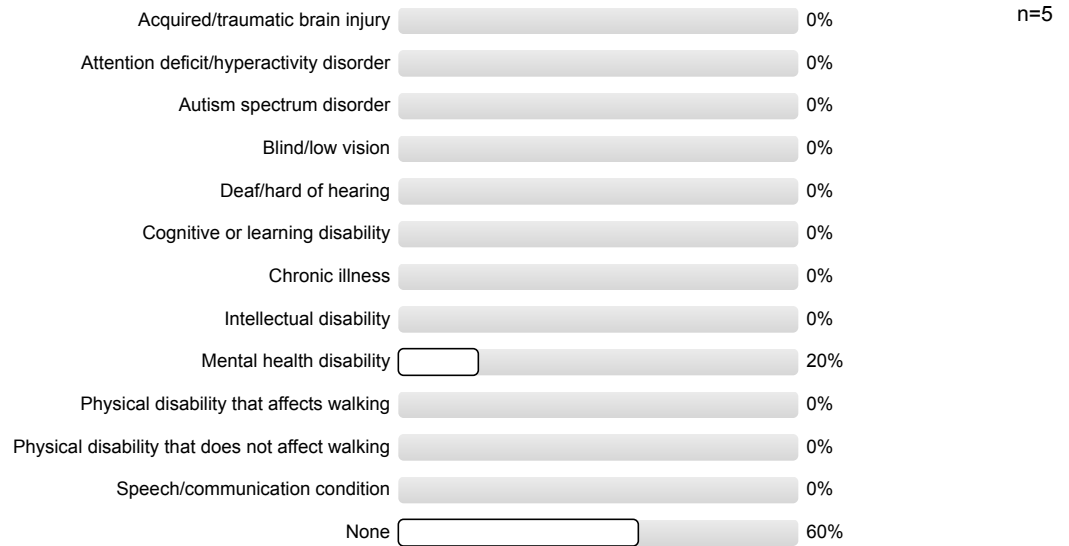

4. Institutional Effectiveness

4.1) The **teaching/learning environment** is *equitable and inclusive* for students at my primary ARC work location.

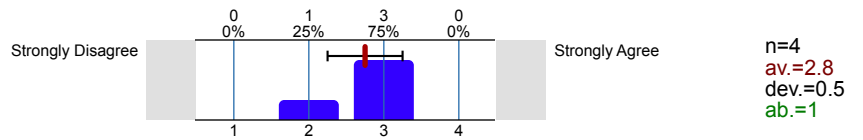

4.2) The **teaching/learning environment** is *safe* for students at my primary ARC work location.

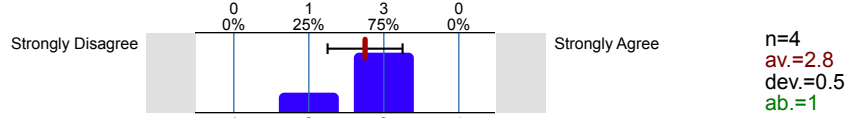

4.3) The **working environment** for students at ARC is *equitable and inclusive*.

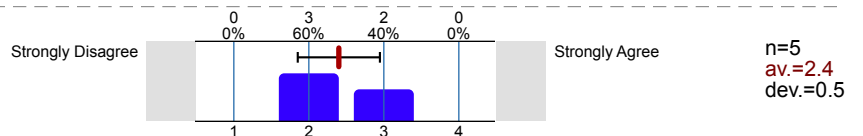

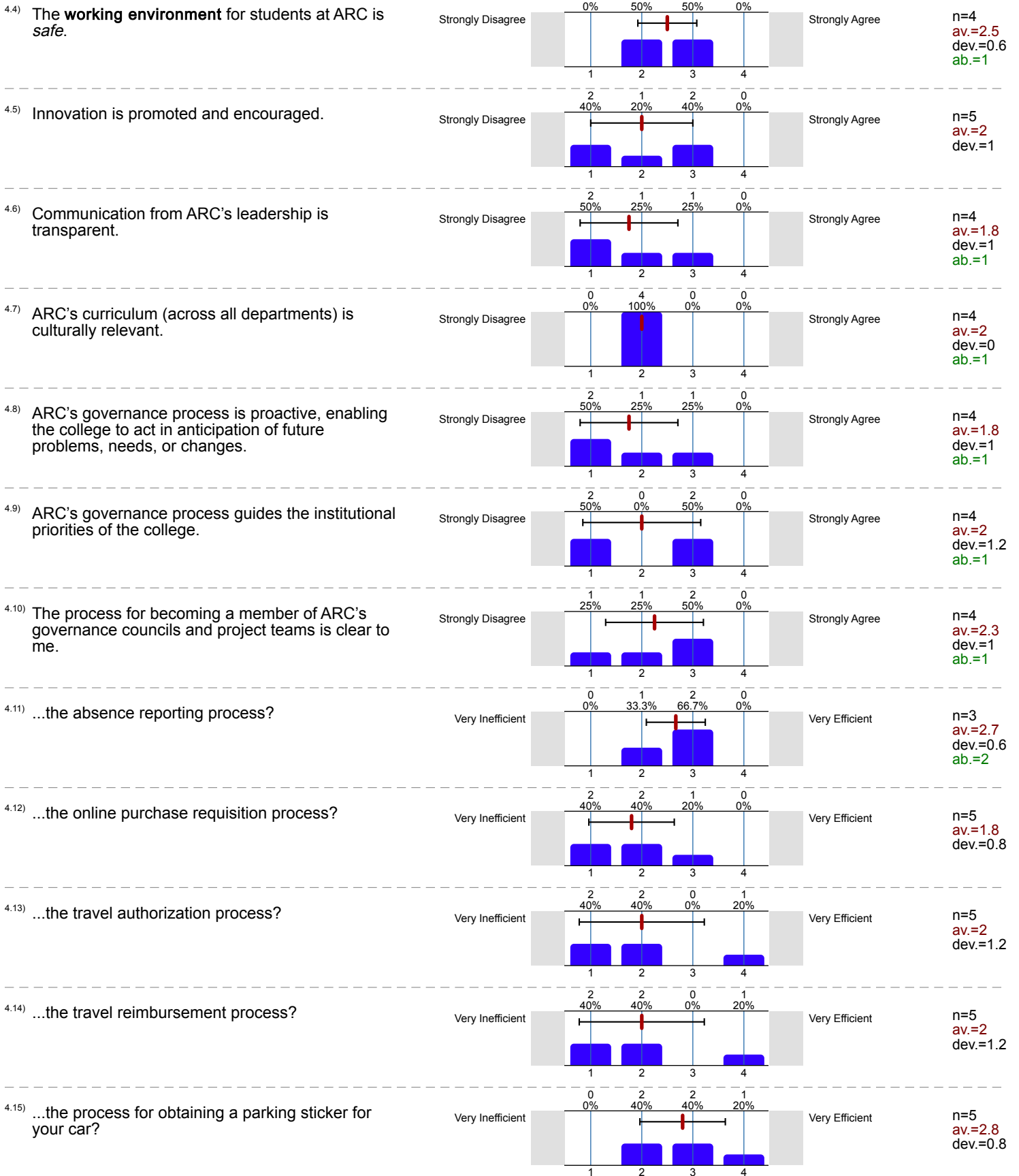

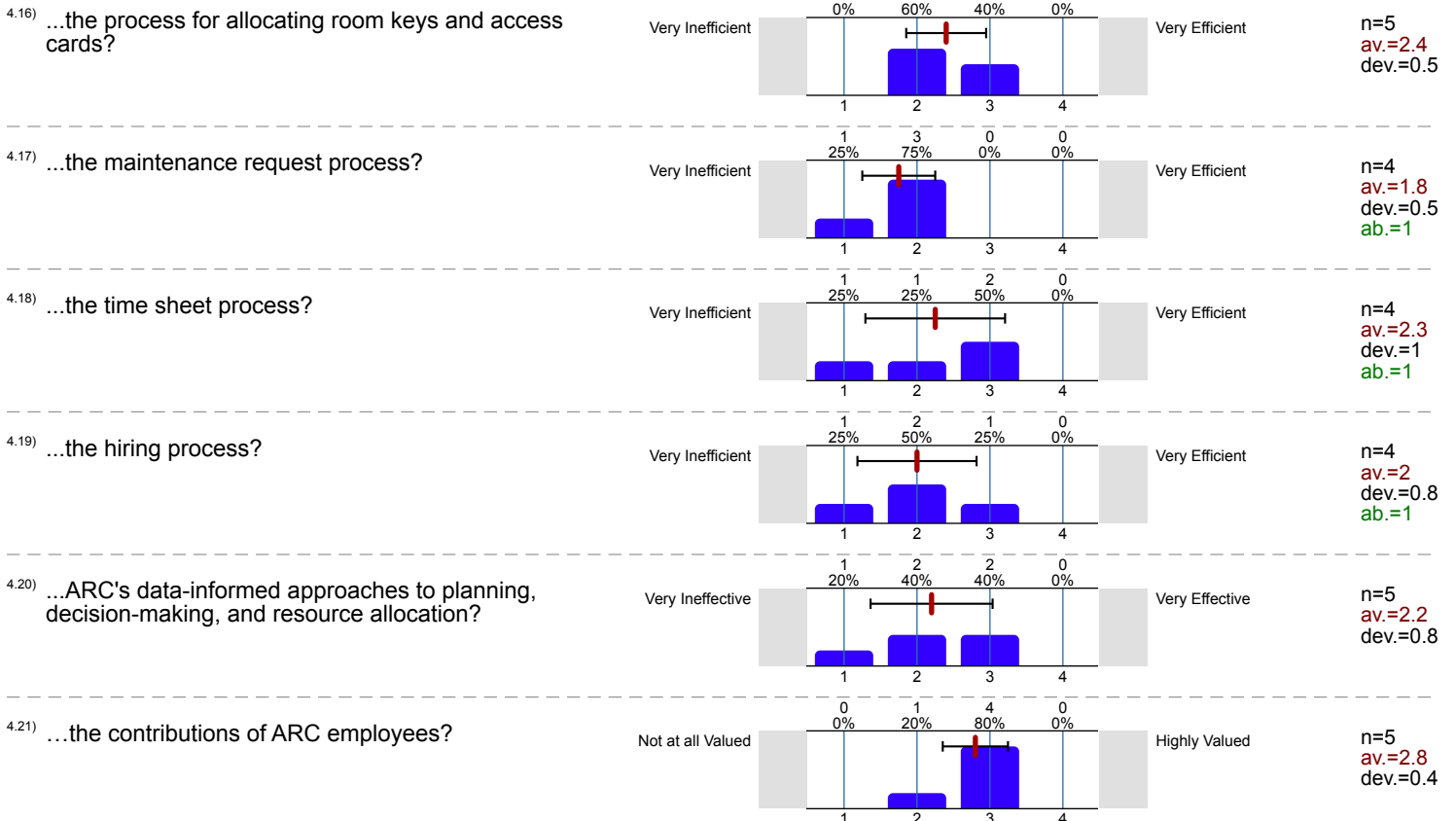

5. Student-Focus

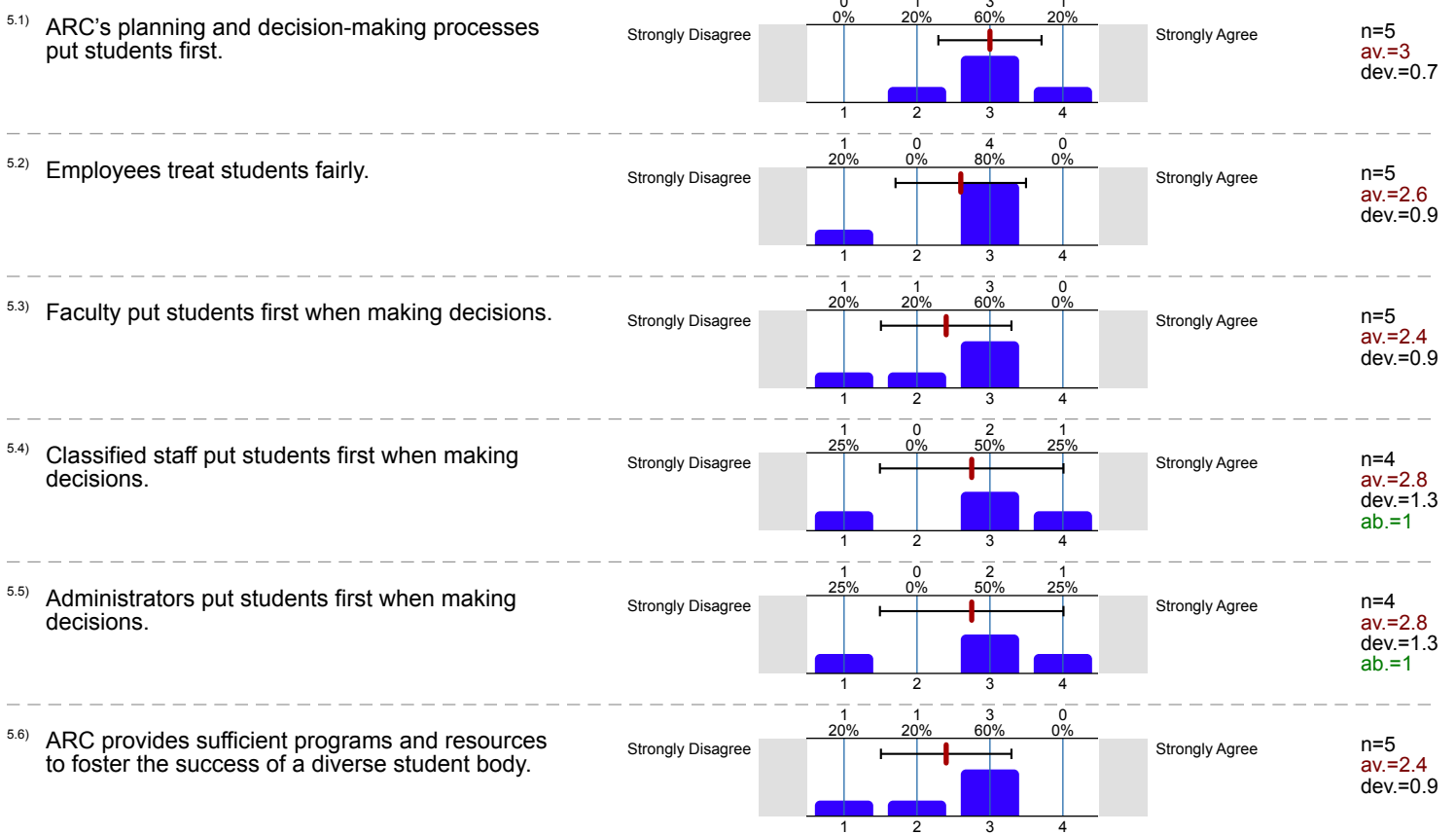

6. Teamwork

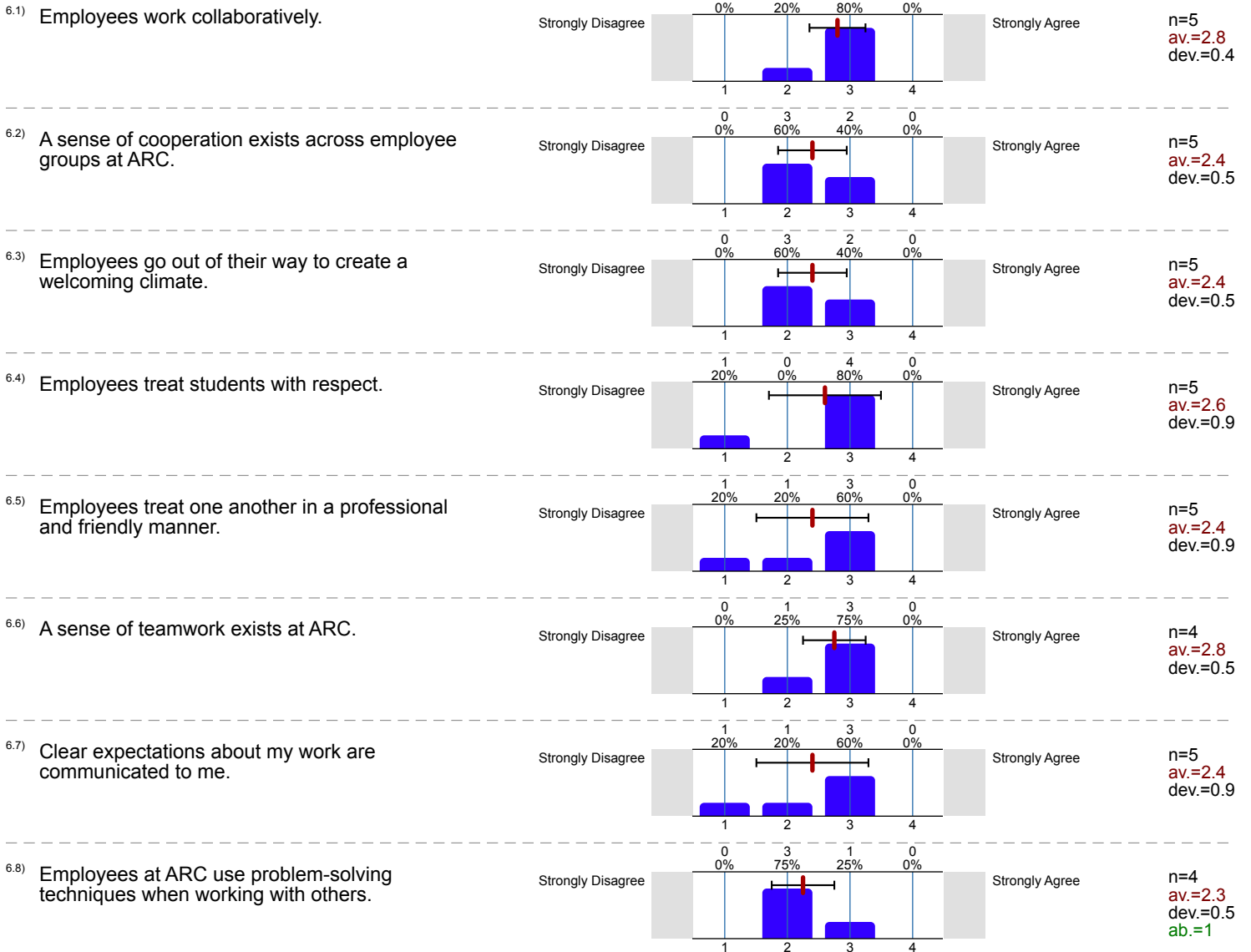

7. Job Satisfaction

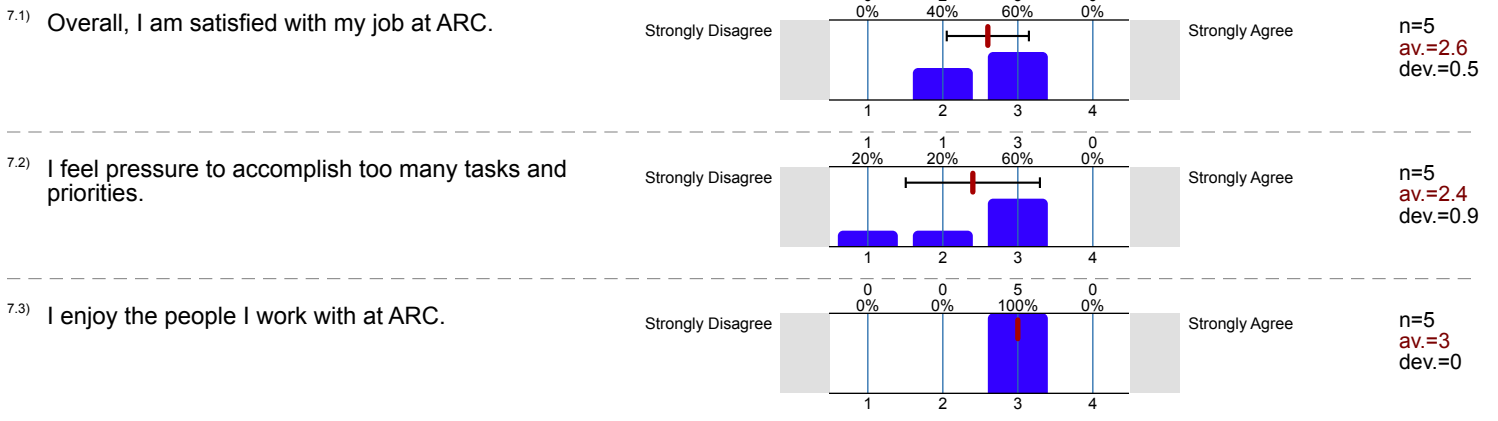

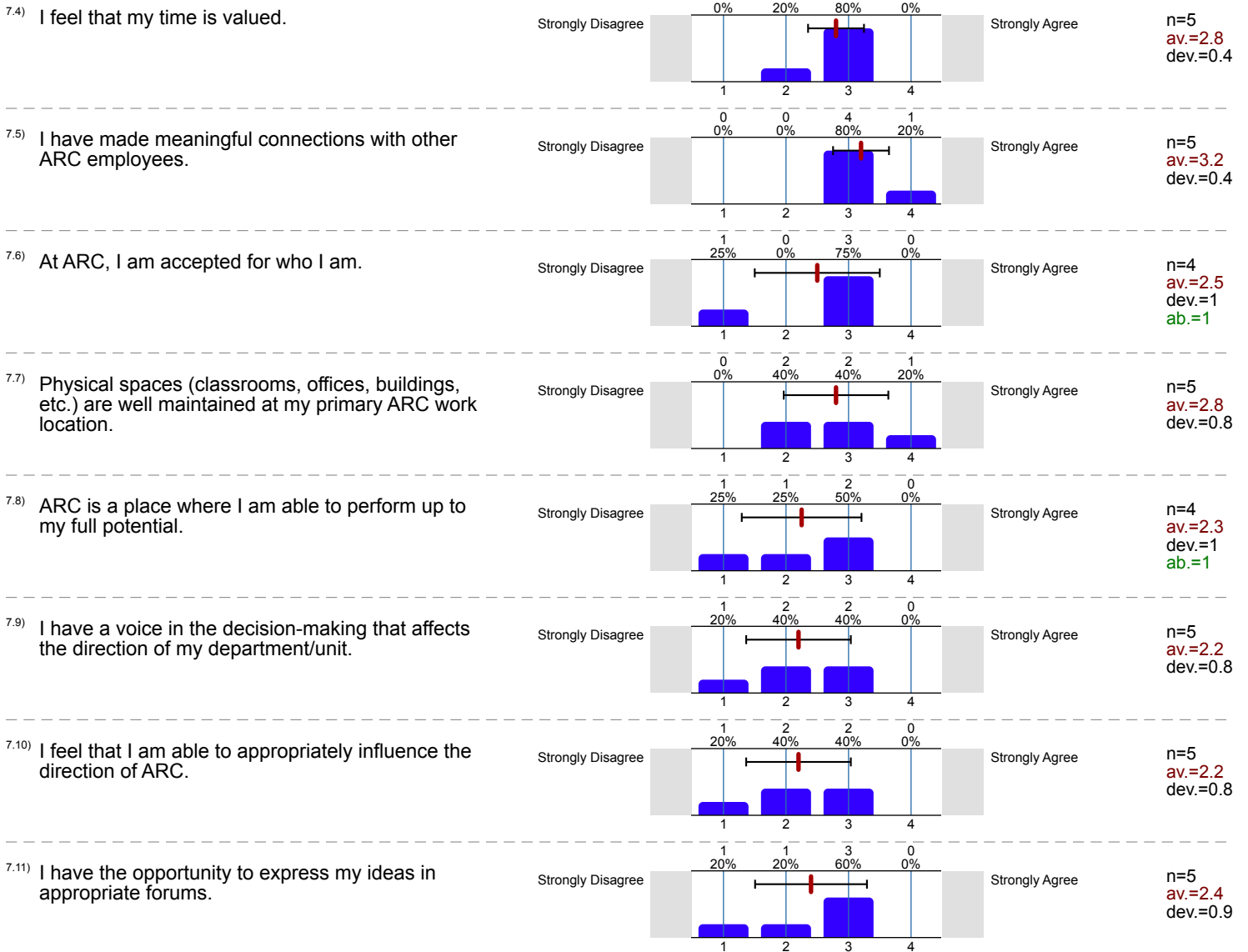

8. Faculty Specific Questions

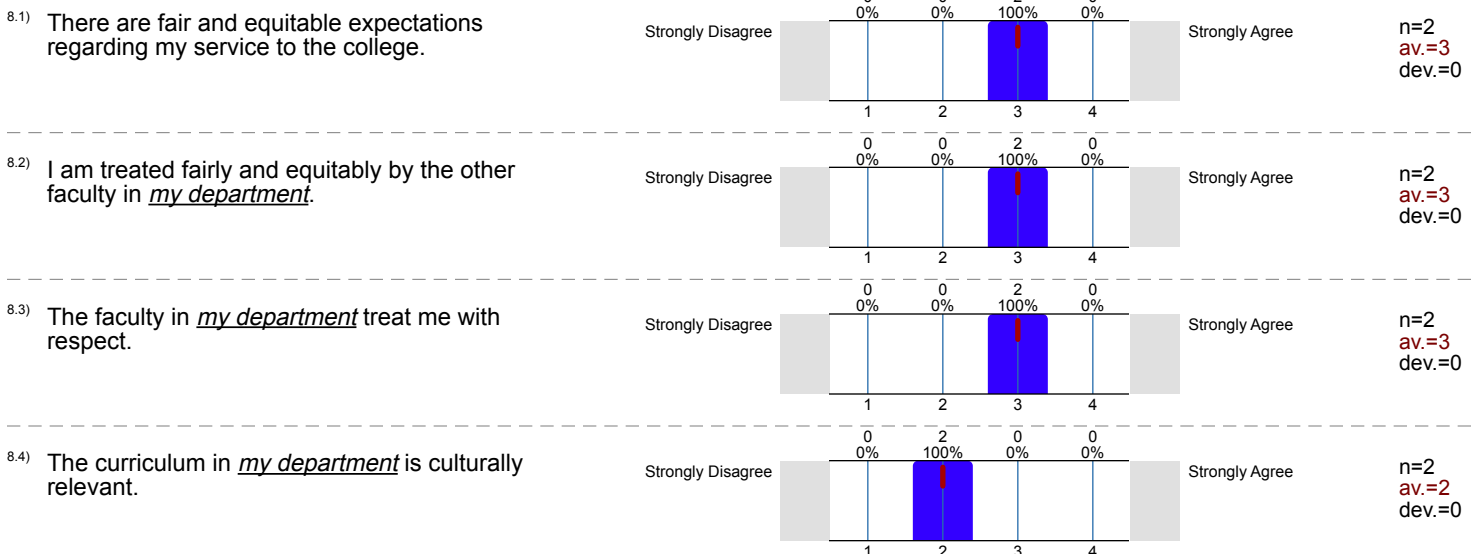

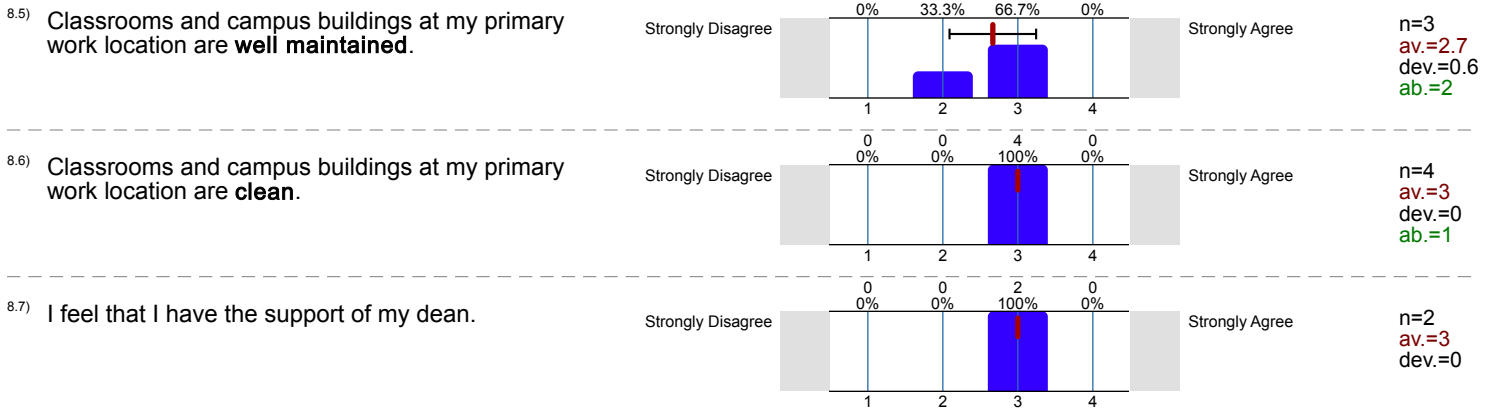

9. Professional Development

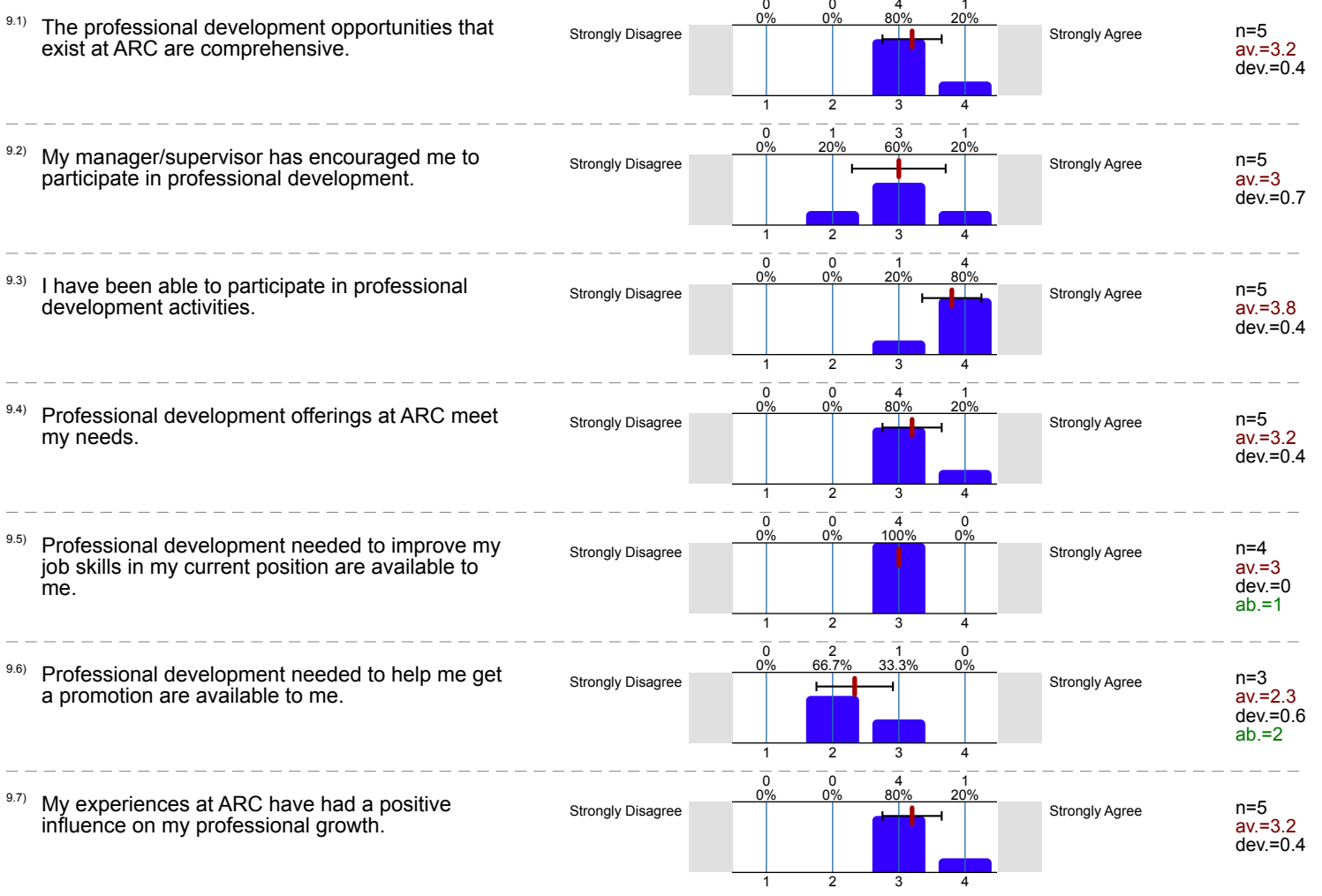

10. Equity, Inclusion, Social Justice Focus



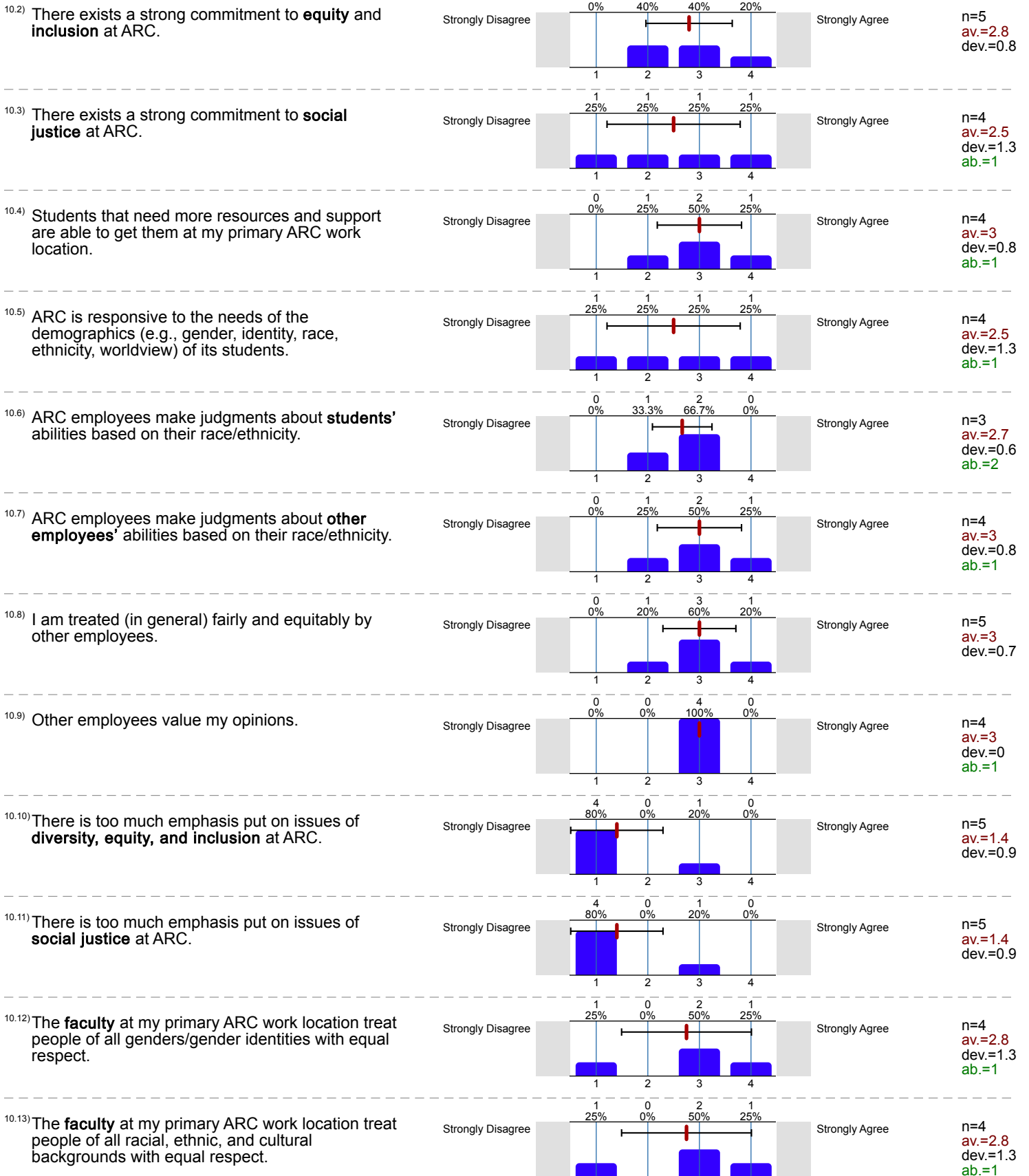

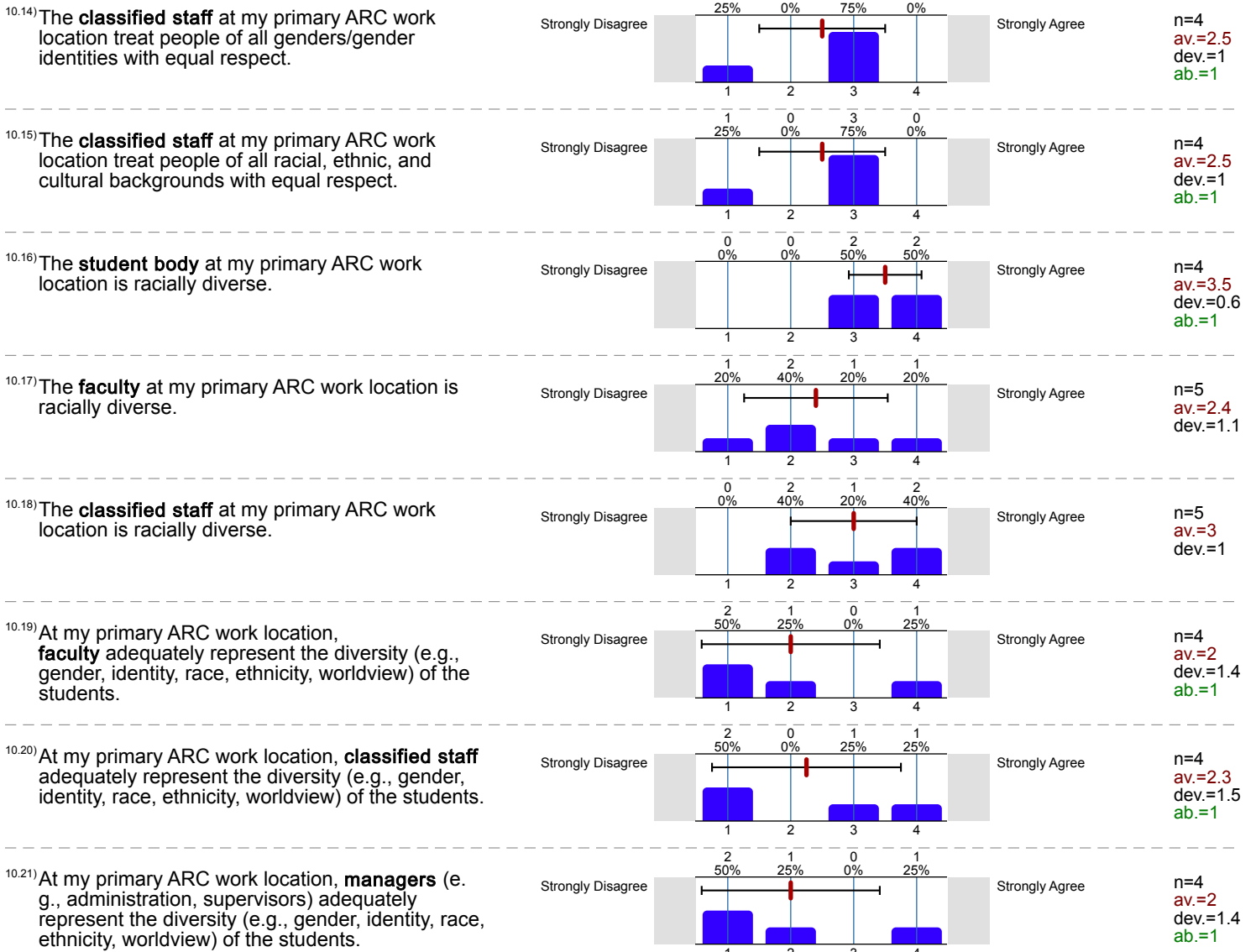

11. Each of the following questions shows a pair of adjectives that are opposite to one another. The six boxes between each pair reflect a range of responses (for example, from a 'Hostile' environment at one end of the range, to a 'Friendly' environment at the other). For each question, mark the one box between each pair of adjectives that best expresses how you feel about your primary ARC work location based on your personal experiences:

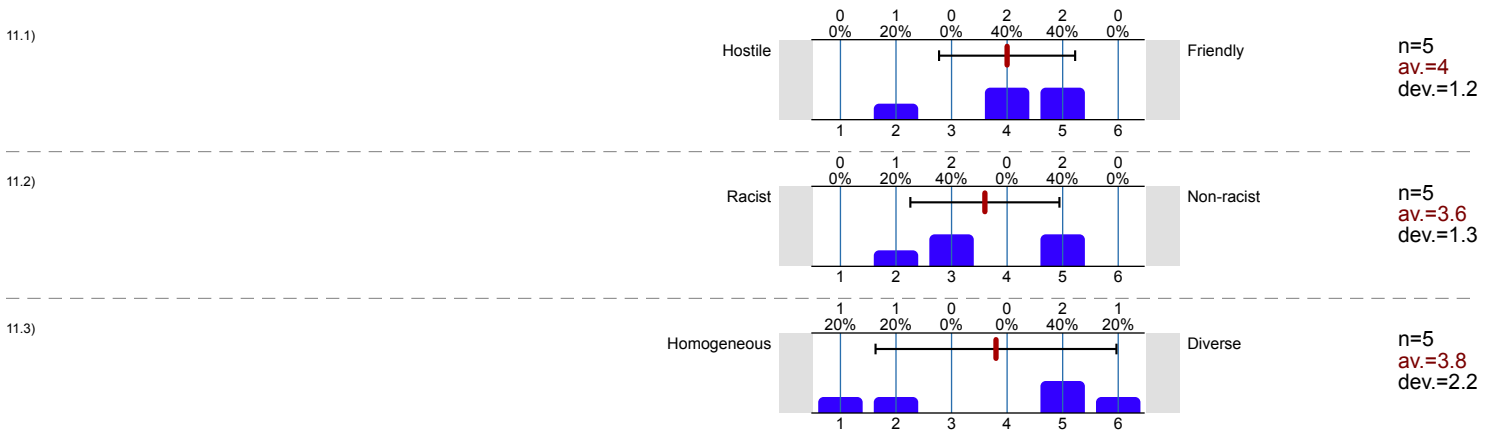

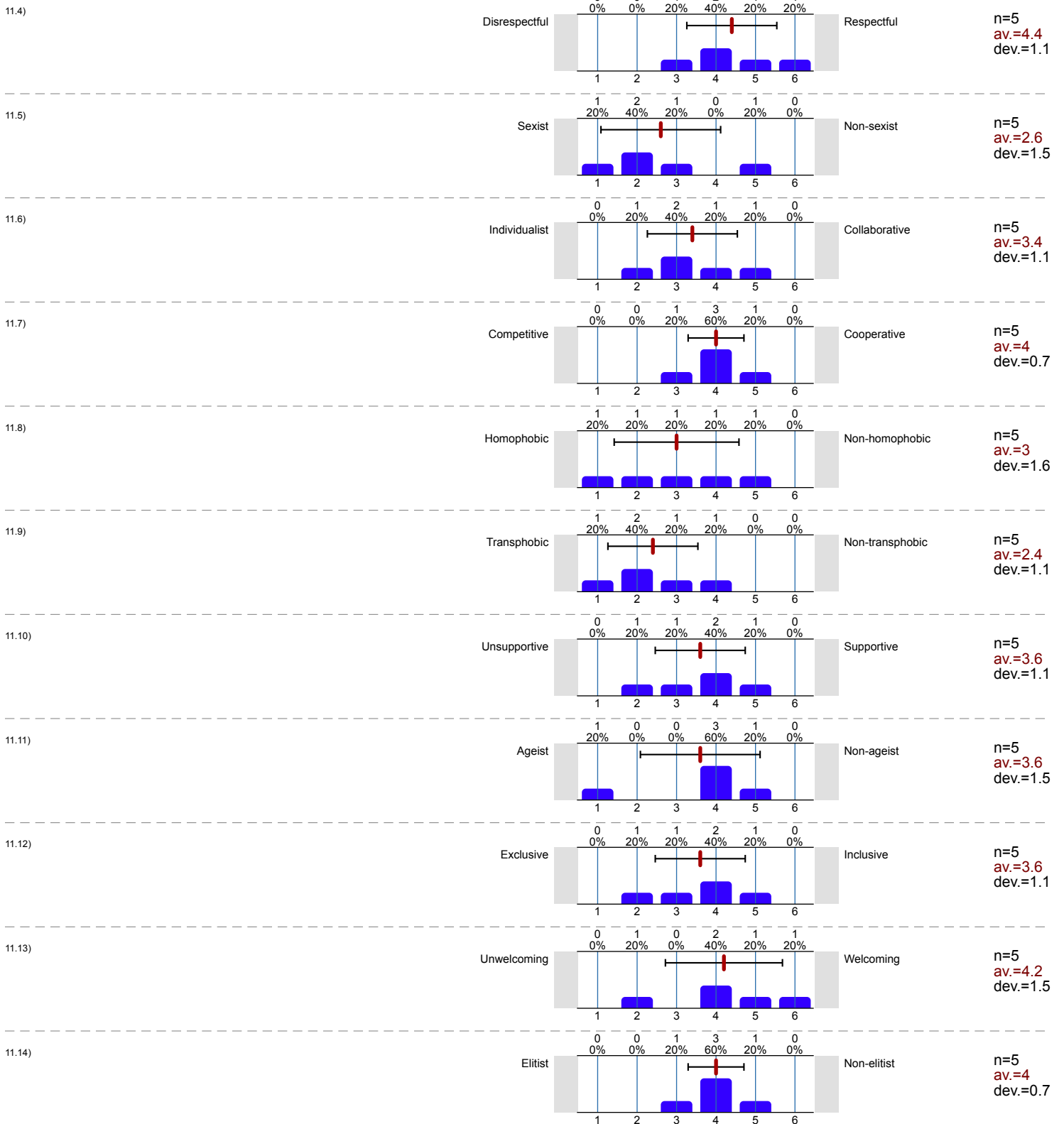

12. During the past 12 months at your primary ARC work location, have you heard anyone... (MARK ALL THAT APPLY)

12.1) ...call someone homophobic names.

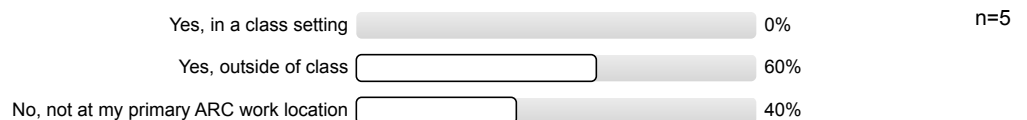

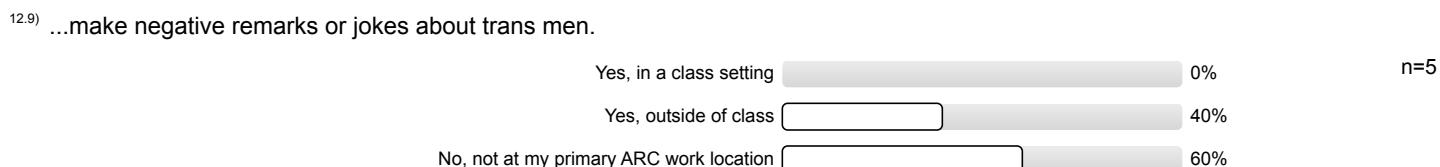
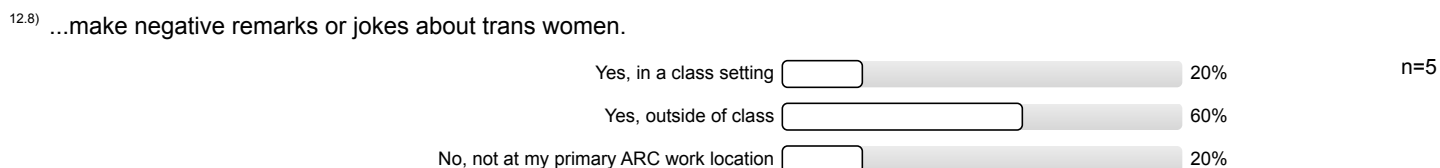
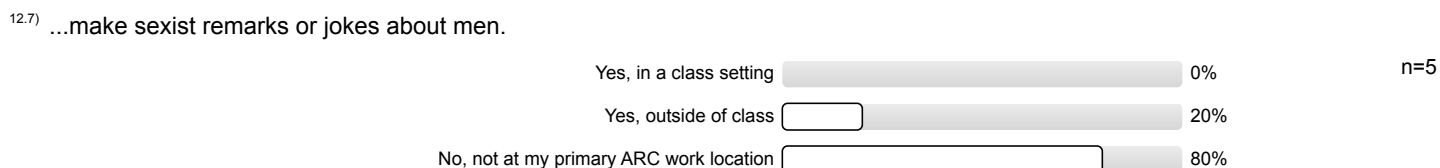
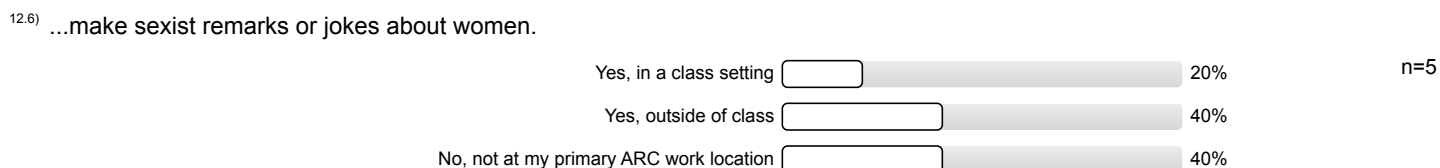
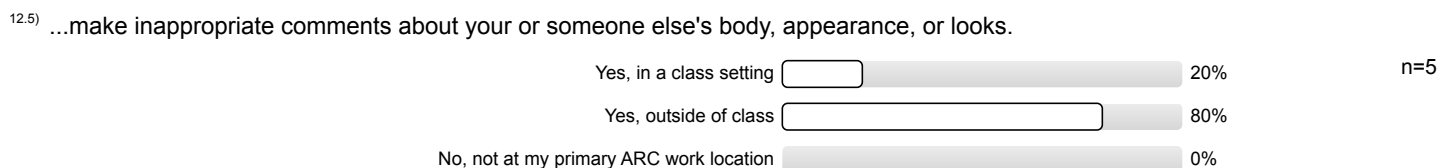
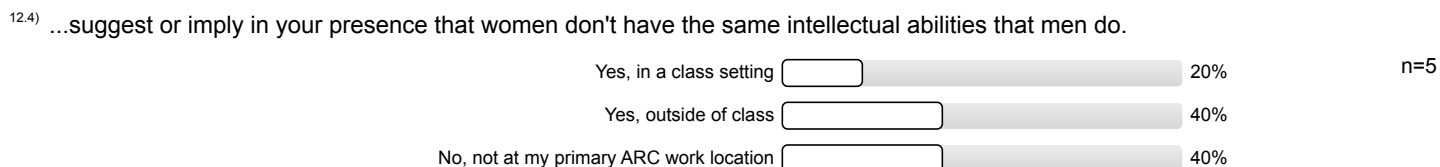
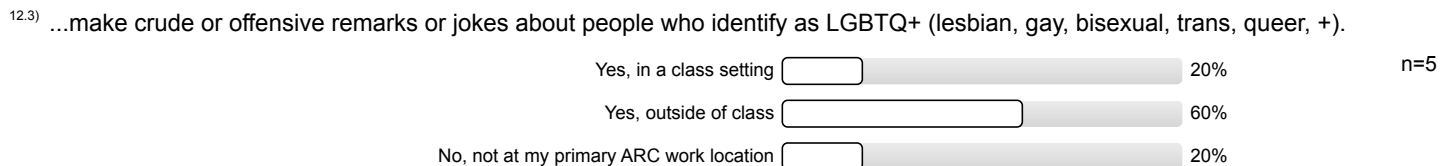
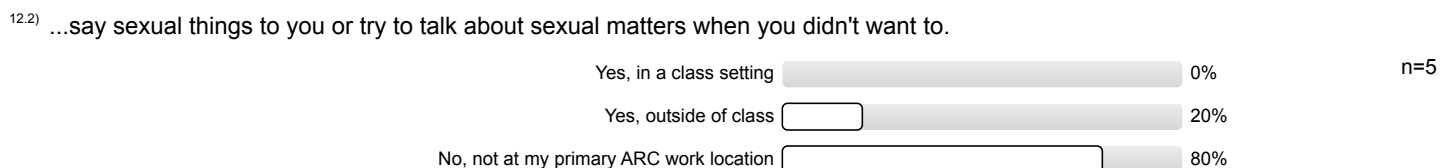

13. Regarding your **physical safety**:

13.1) During the past 12 months, have you been concerned for your **physical** safety at your primary ARC work location?

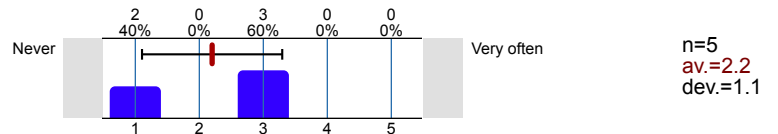

13.2) During the past 12 months, have you avoided any of the following areas at your primary ARC work location due to concerns for your **physical** safety (mark all that apply)?

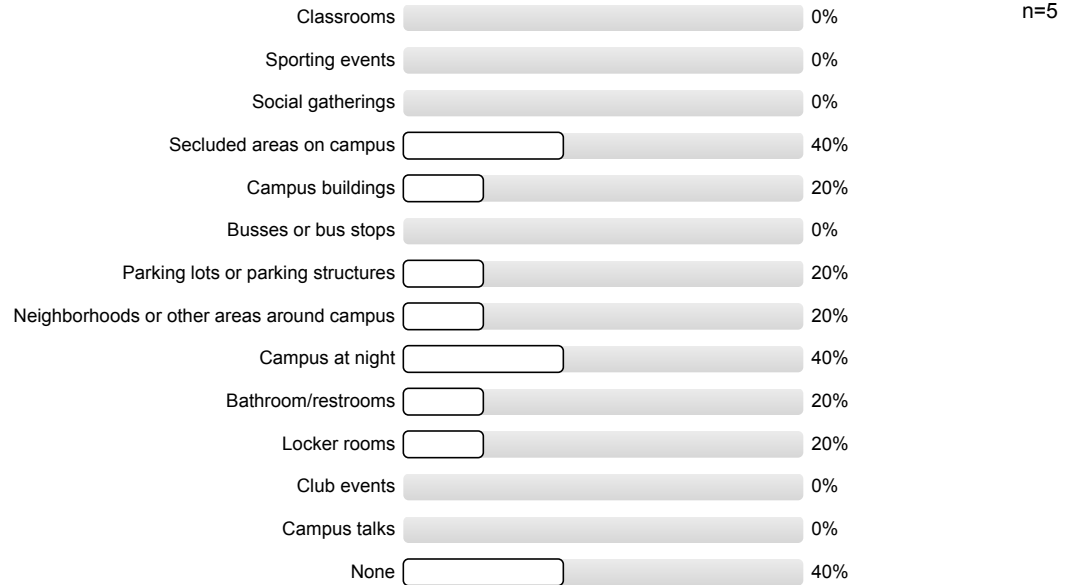

13.4) Other students

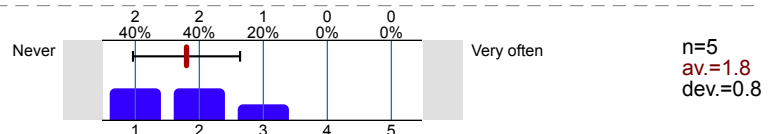

13.5) Instructors

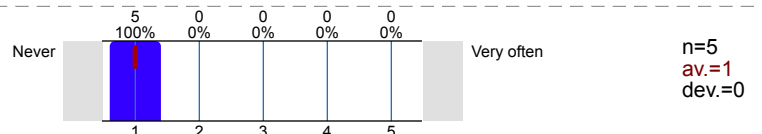

13.6) Staff

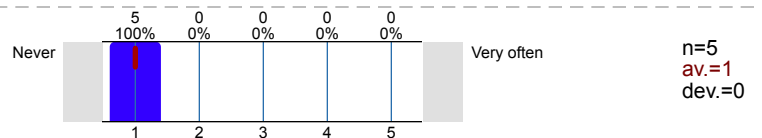

14. Regarding your **emotional safety**:

14.1) During the past 12 months, have you been concerned for your **emotional** safety at your primary ARC work location?

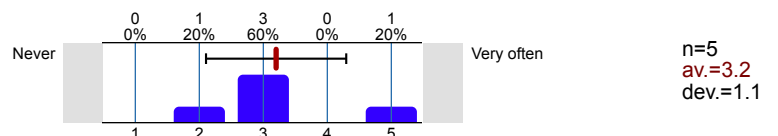

14.2) During the past 12 months, have you avoided any of the following areas at your primary ARC work location due to concerns for your **emotional** safety? (mark all that apply)

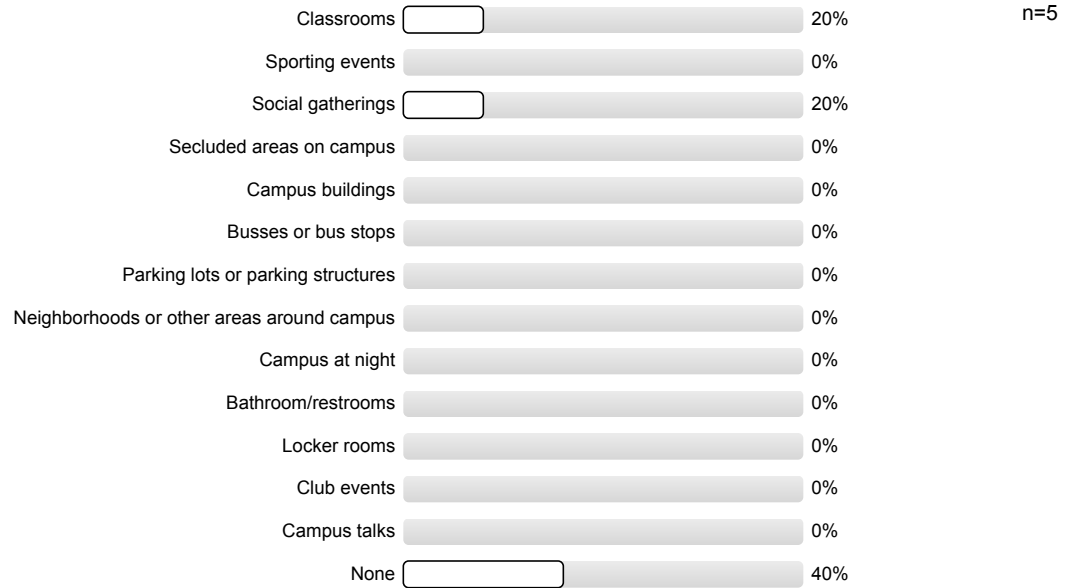

14.4) Other students

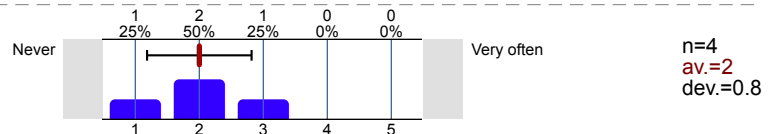

14.5) Instructors

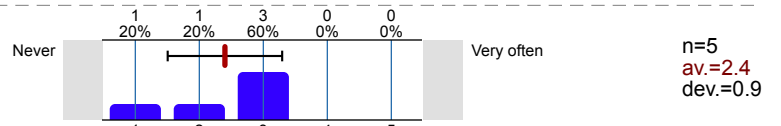

14.6) Staff

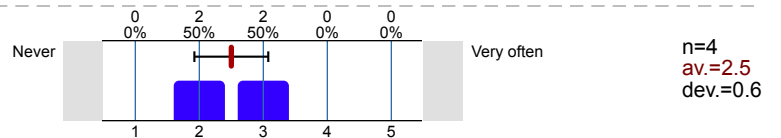

15. Regarding your primary ARC work location:

15.1) Discrimination



15.2) Threats of physical violence



15.3) Physical violence



15.4) Threats of emotional violence



15.5) Emotional violence



15.6) Sexual harassment

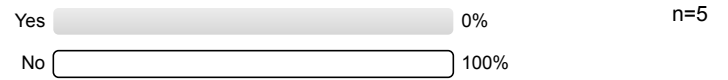

15.7) Other harassment

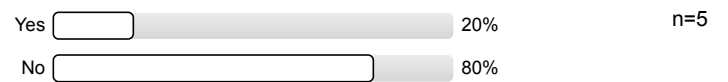

15.8) Sexual assault



15.9) Unwanted sexual advances

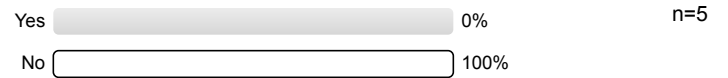

15.10) Verbal threats



15.11) Discrimination



15.12) Threats of physical violence



15.13) Physical violence

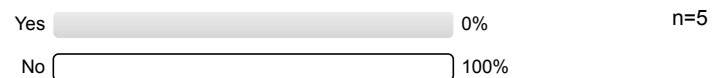

15.14) Threats of emotional violence



n=5

15.15) Emotional violence

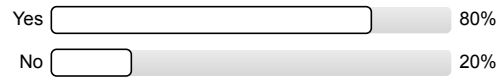

n=5

15.16) Sexual harassment



n=5

15.17) Other harassment



n=5

15.18) Sexual assault



n=5

15.19) Unwanted sexual advances

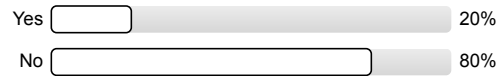

n=5

15.20) Verbal threats



n=5

16. During the past 12 months, have you experienced microaggressions at your primary ARC work location with regard to your...

16.1) ...gender/gender identity

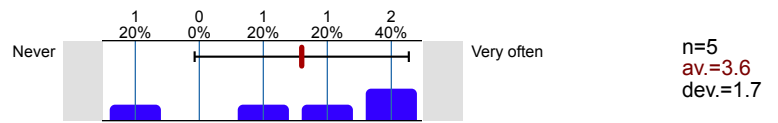

n=5
av.=3.6
dev.=1.7

16.2) ...sexual orientation

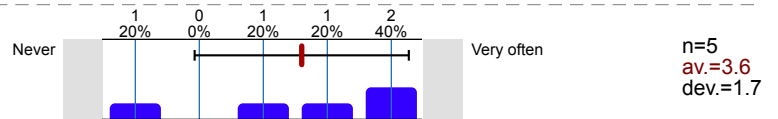

n=5
av.=3.6
dev.=1.7

16.3) ...racial, ethnic, or cultural identity

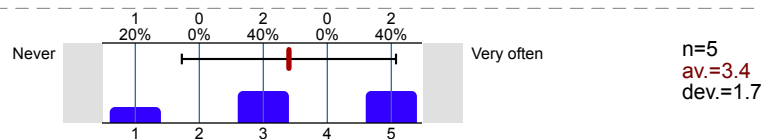

n=5
av.=3.4
dev.=1.7

17. During the past 12 months, do you feel YOU have been mistreated *by students* at your primary ARC work location because of your:

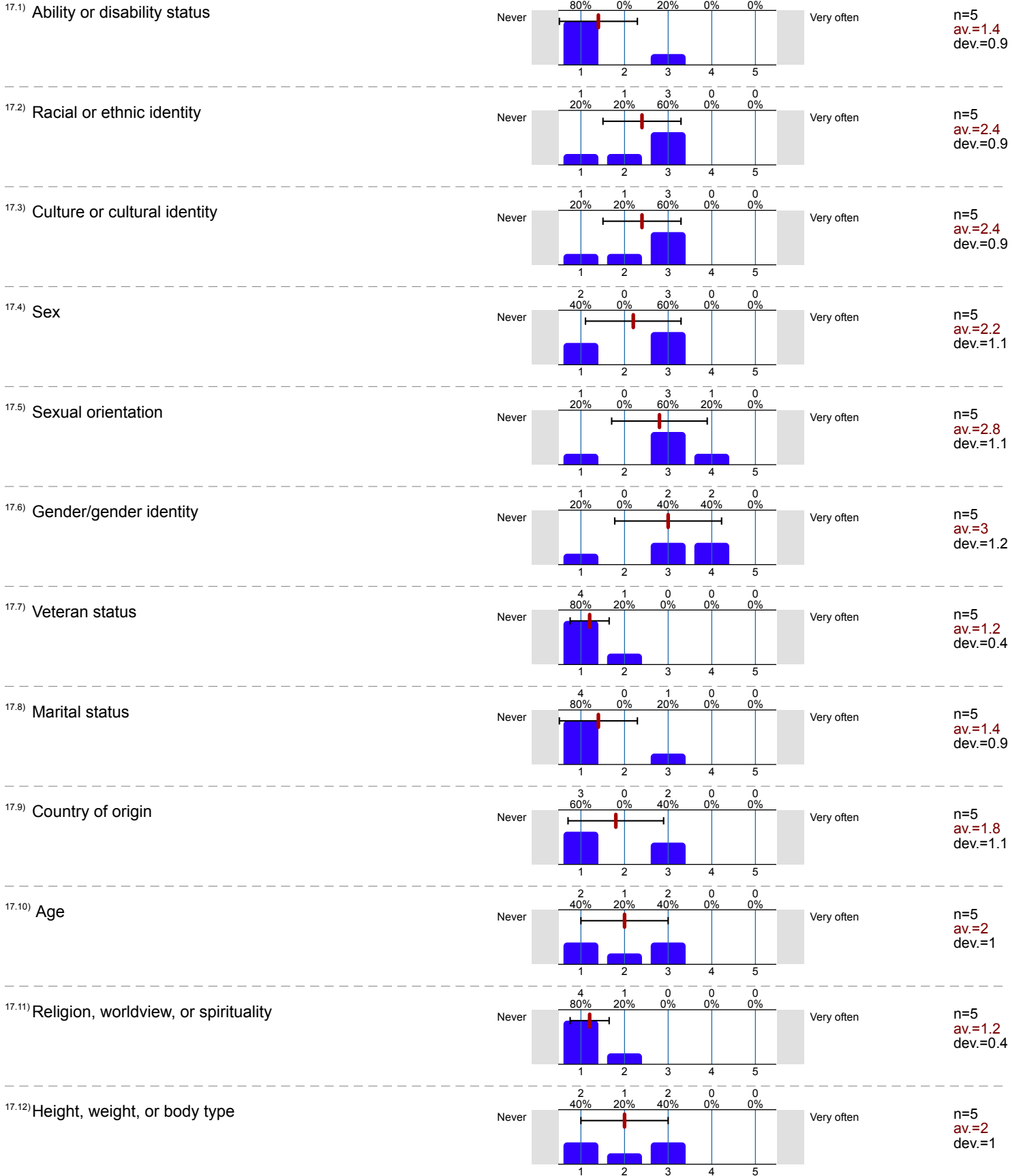

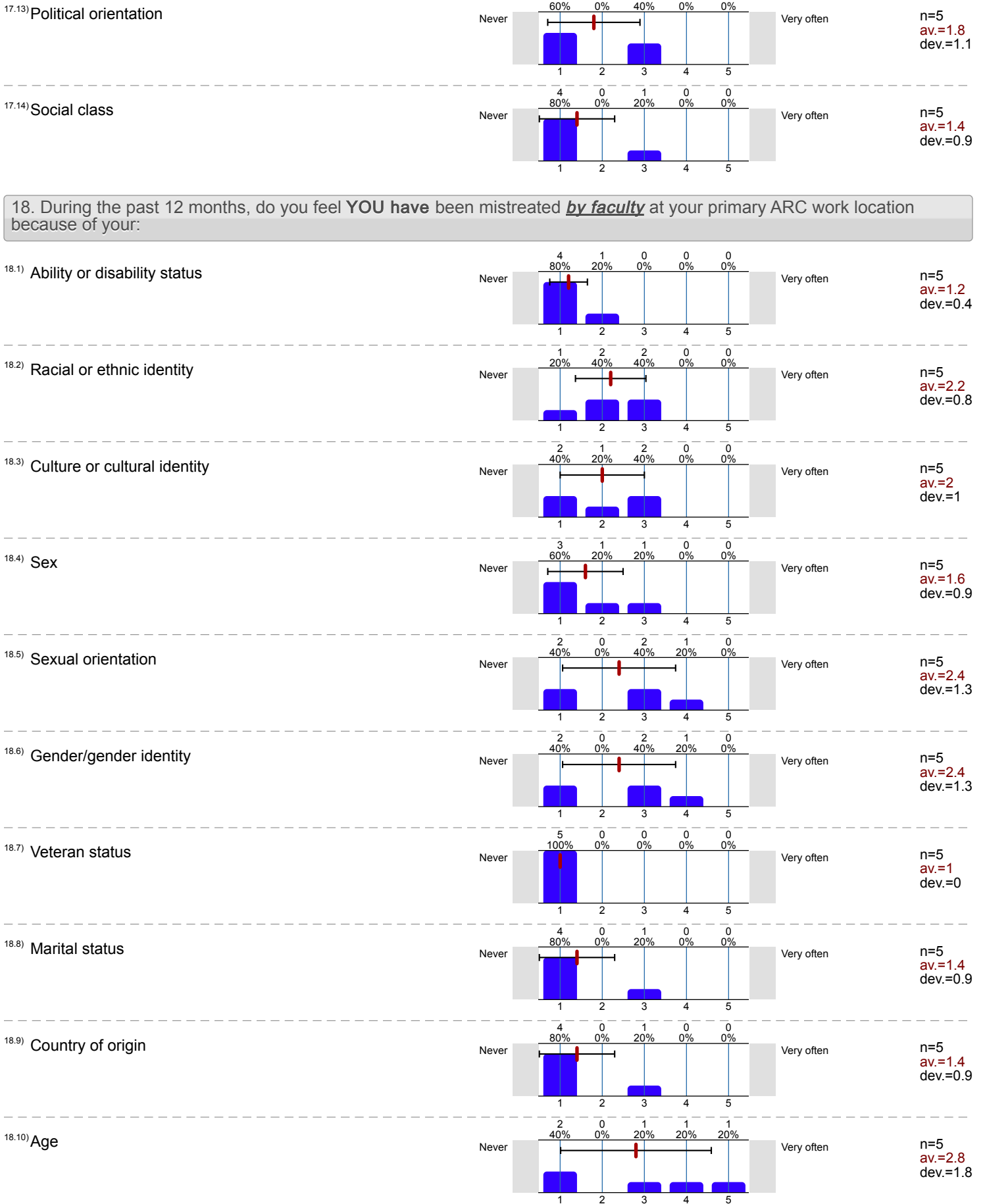

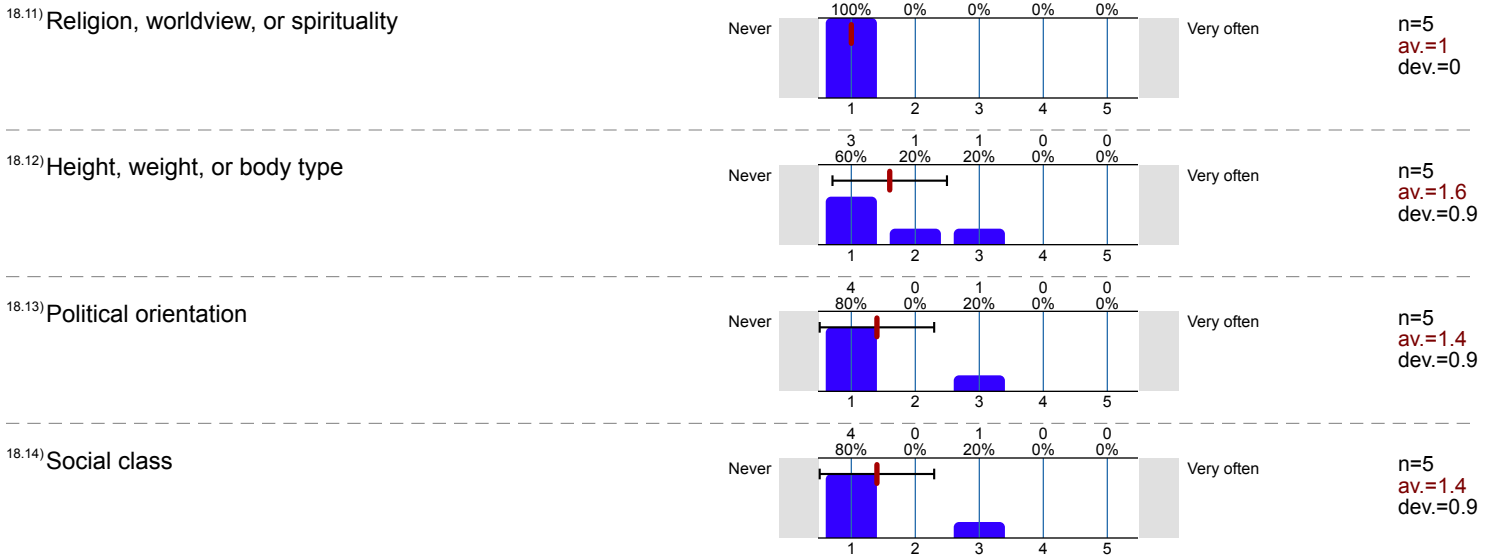

19. During the past 12 months, do you feel **YOU have** been mistreated *by classified staff* at your primary ARC work location because of your:

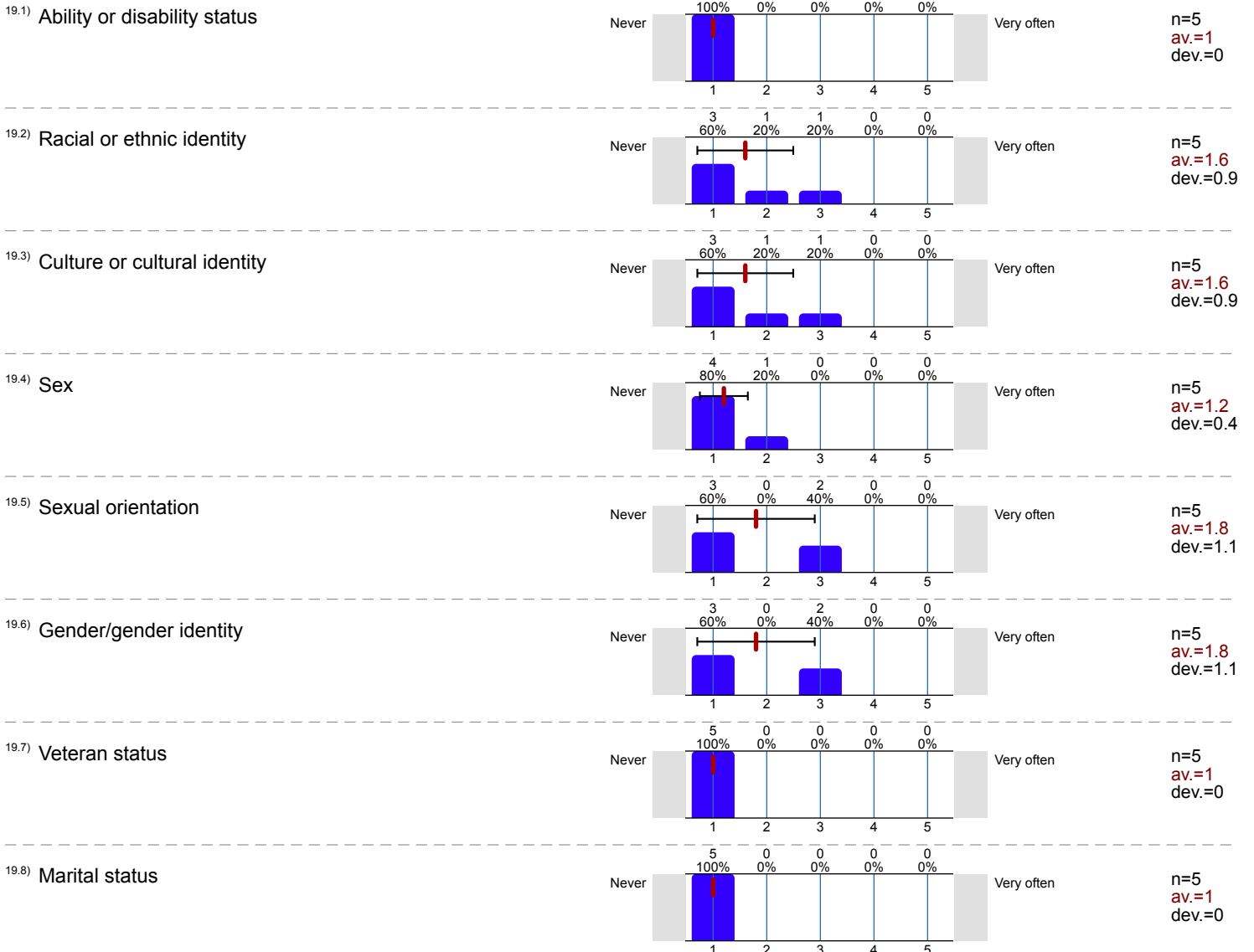

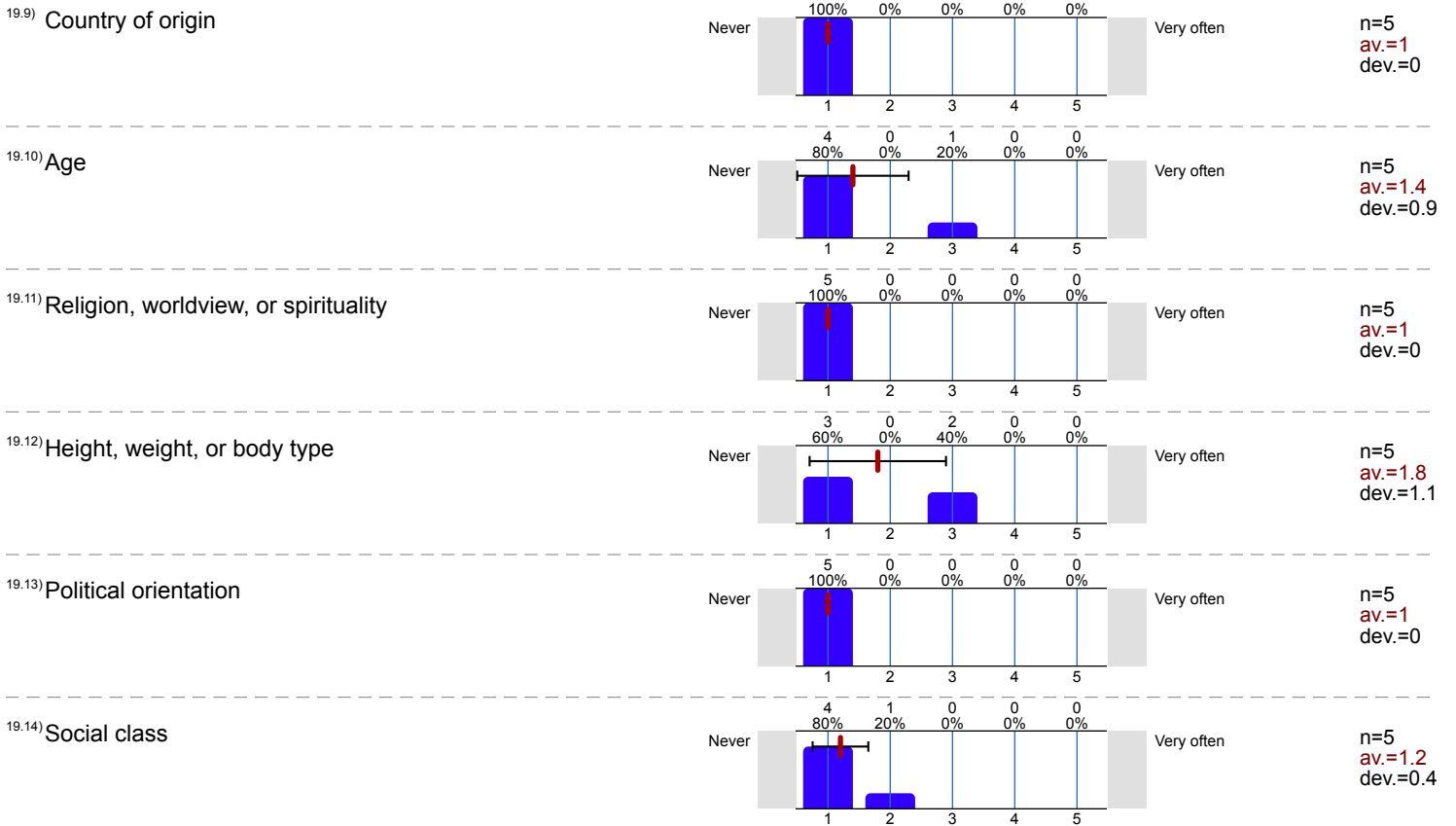

20. During the past 12 months, do you feel **YOU** have been mistreated *by managers (administrators, supervisors)* at your primary ARC work location because of your:

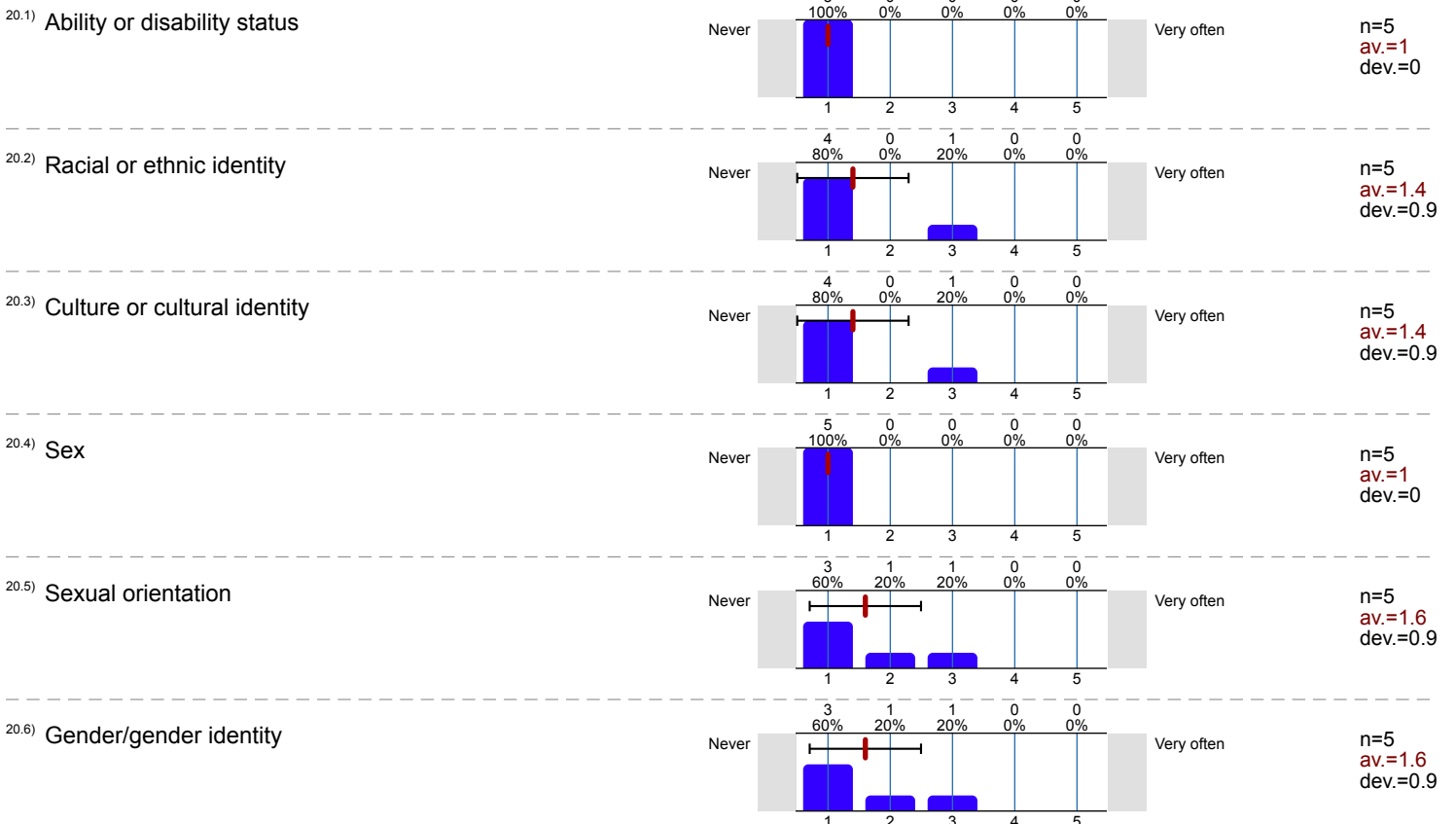

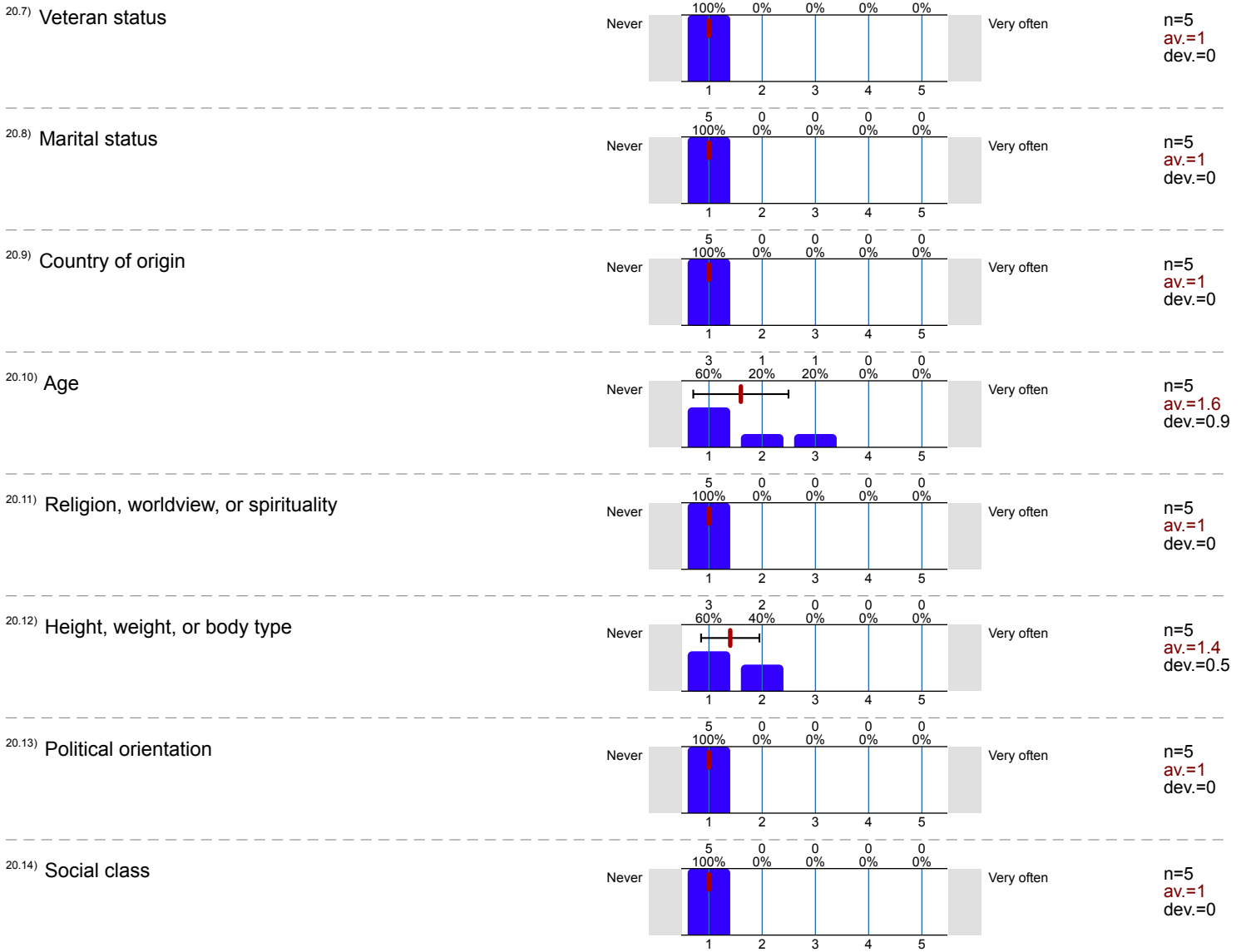

21. During the past 12 months, have you seen faculty, classified staff, or managers mistreat students at your primary ARC work location because of their:

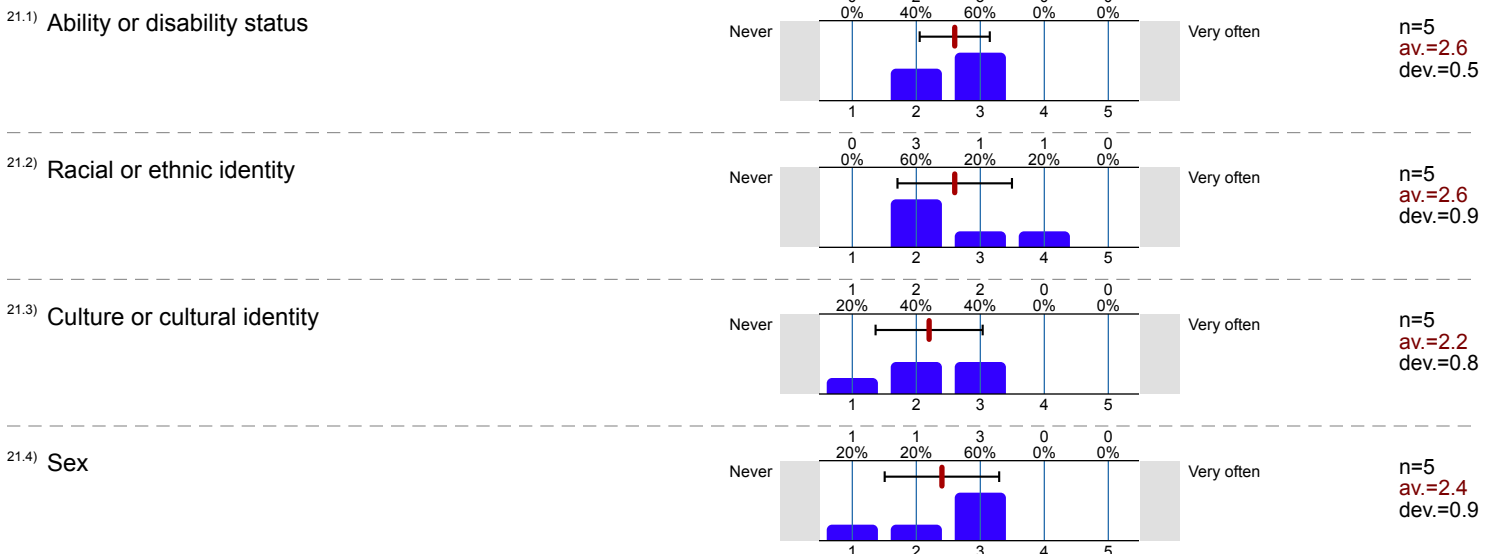

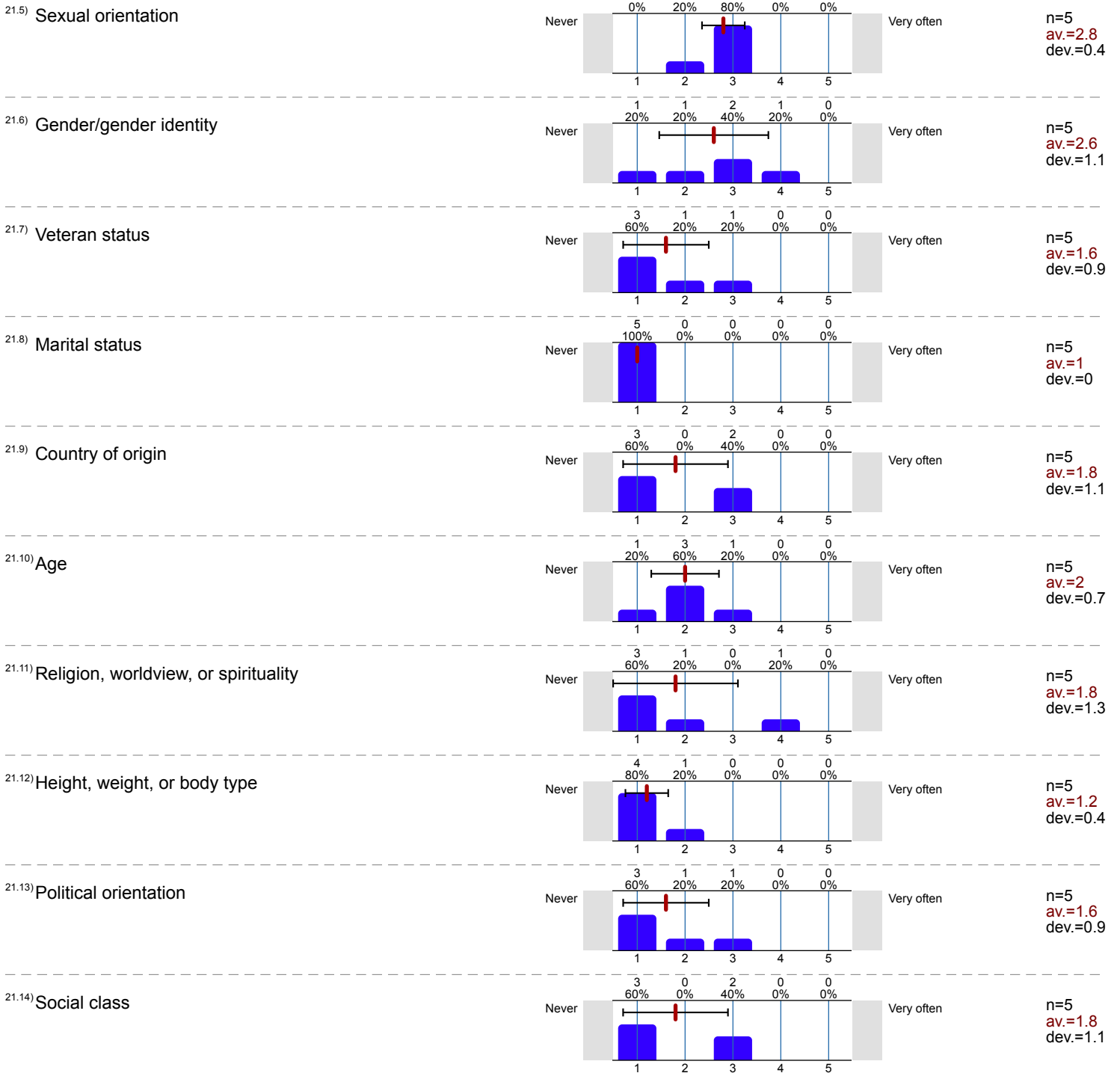

22. During the past 12 months, have you seen faculty, classified staff, or managers mistreat other faculty, classified staff, or managers at your primary ARC work location because of their:

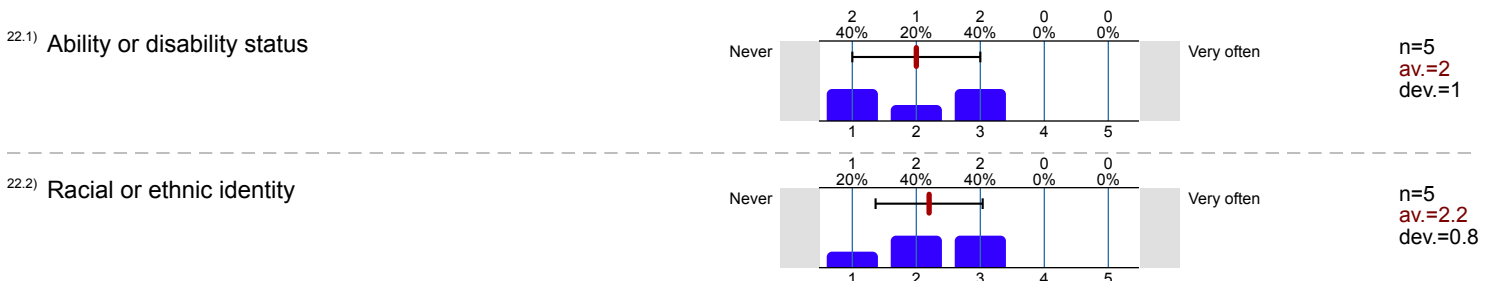

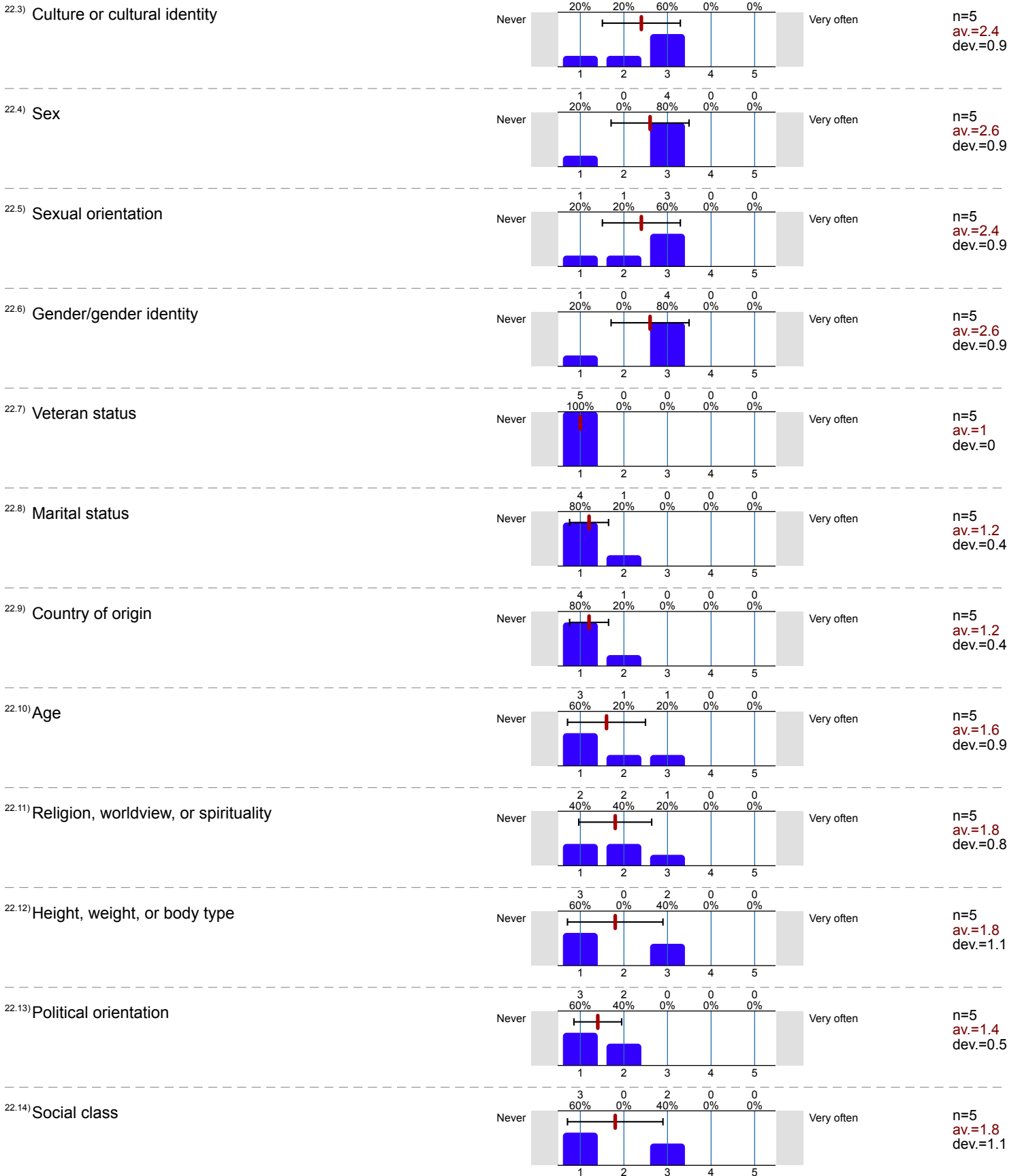

23. During the past 12 months at your primary ARC work location, how often have you interacted in a meaningful way with people...

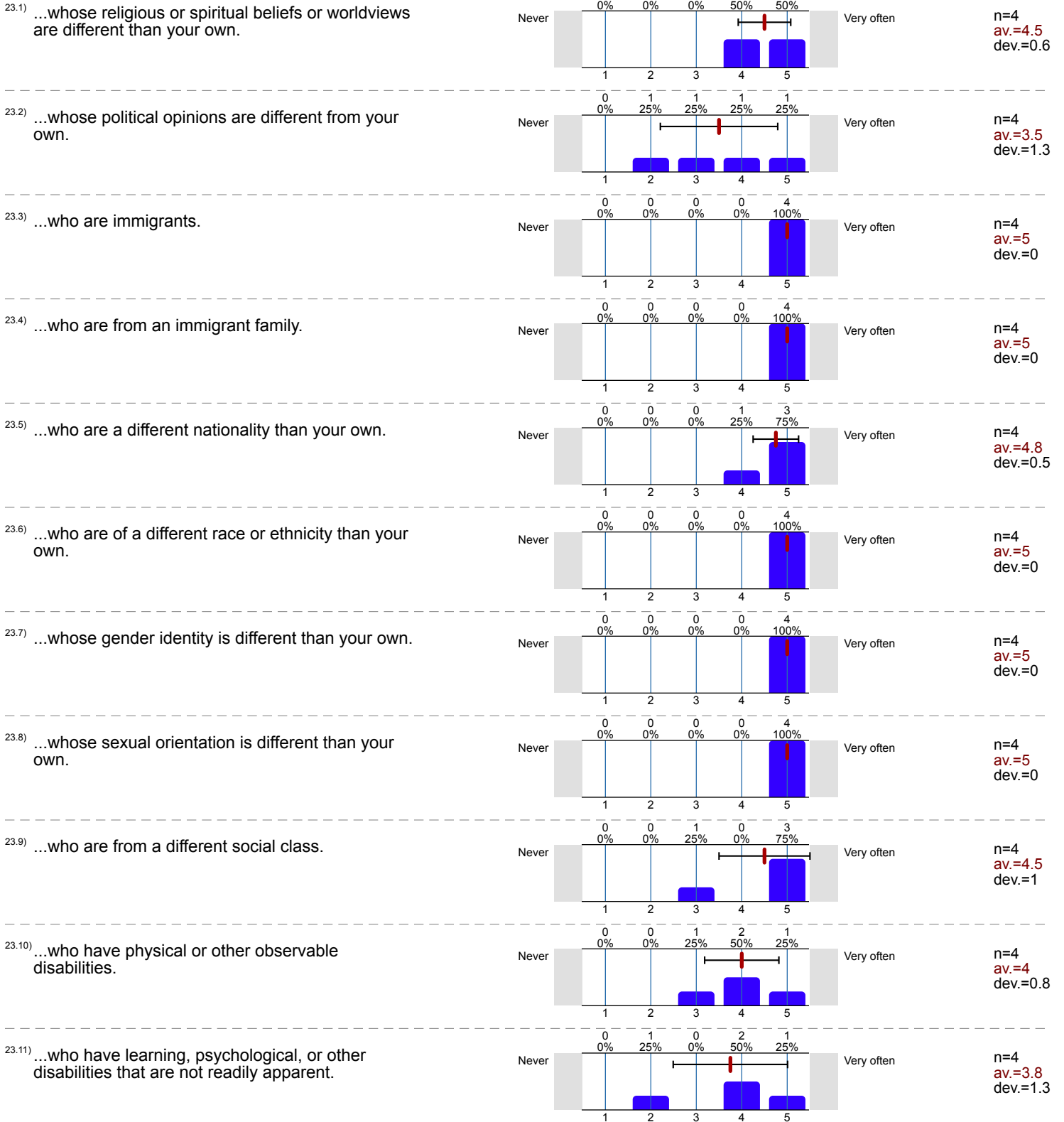

24. Overall campus climate at your primary ARC work location:

24.1) During the past 12 months, how satisfied or dissatisfied are you with the overall campus climate/environment that you have experienced at your primary ARC work location?

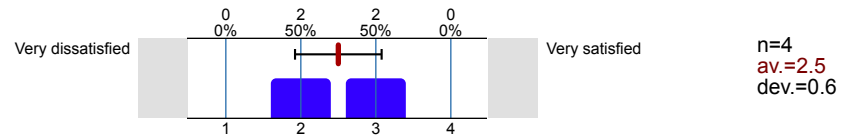

Comments Report

3. Demographics

3.2) Other gender identity:

■ Gender fluid

■ I'm not entirely confident about my gender identity - I mostly identify as a cisgender woman because that is what I was assigned at birth and spent my whole life being called, but I'm not sure what being a certain gender is supposed to "feel" like, or why gender is something that people emphasize. I also enjoy dressing as a stereotypical cisgendered man at times, so I'm not sure if I am nonbinary, gender fluid, or just cisgendered and confused.

3.4) Other sexual orientation:

■ Queer

3.7) Aside from how you responded above, please list in the text box below all of the specific races, ethnicities, tribes and cultures with which you **strongly** identify (for example, Jamaican, Columbian, Punjabi, Cherokee, Armenian).

■ Guatemalan, Mexican, Xicanx

■ I HATE the term Hispanic. Also, many folks use Latinx instead of or in addition to Latina or Latino.

■ Korean American and European American

3.9) Other religions, worldviews, or spiritual backgrounds:

■ What about Decline to State?

3.14) Other disabilities:

■ Epilepsy

13. Regarding your personal physical safety:

13.3) Other areas you have avoided at your primary ARC work location due to concerns for your physical safety:

■ The walkway from upper parking area to lower parking area. I avoid it because there is overgrowth from bushes and the walk gets muddy. Also, it's wide enough for only one person at a time.

14. Regarding your emotional safety:

14.3) Other areas you have avoided at your primary ARC work location due to concern for your emotional safety:

■ Department meetings

■ Meetings