

# African American Employees

No. of responses = 16



## Survey Results

### Legend

Question text

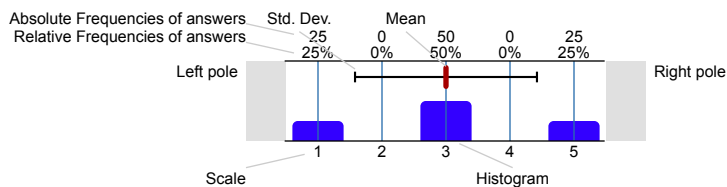

n=No. of responses  
 av.=Mean  
 dev.=Std. Dev.  
 ab.=Abstention

## 2. Employee Info

### 2.1) Primary Employment Classification:

Faculty, Full-Time Teaching	<input type="checkbox"/>	6.7%	n=15
Faculty, Full-Time Non-Teaching (Counselors, Librarians)	<input type="checkbox"/>	20%	
Faculty, Adjunct Teaching	<input type="checkbox"/>	6.7%	
Faculty, Adjunct Non-Teaching (Counselors, Librarians)	<input type="checkbox"/>	6.7%	
Classified, Full-Time Permanent	<input type="checkbox"/>	53.3%	
Classified, Part-Time Permanent	<input type="checkbox"/>	0%	
Supervisor	<input type="checkbox"/>	0%	
Administrator	<input type="checkbox"/>	6.7%	

### 2.2) Years worked at ARC (any location):

less than 1 year	<input type="checkbox"/>	12.5%	n=16
1 to 4 years	<input type="checkbox"/>	12.5%	
5 to 9 years	<input type="checkbox"/>	25%	
10 to 14 years	<input type="checkbox"/>	25%	
15 to 19 years	<input type="checkbox"/>	12.5%	
20 years or more	<input type="checkbox"/>	12.5%	

### 2.3) Primary work location at ARC:

ARC Main Campus	<input type="checkbox"/>	87.5%	n=16
Natomas Center	<input type="checkbox"/>	12.5%	
McClellan Center	<input type="checkbox"/>	0%	
Mather Center	<input type="checkbox"/>	0%	

## 3. Demographics

3.1) What is your gender identity? (MARK ALL THAT APPLY)

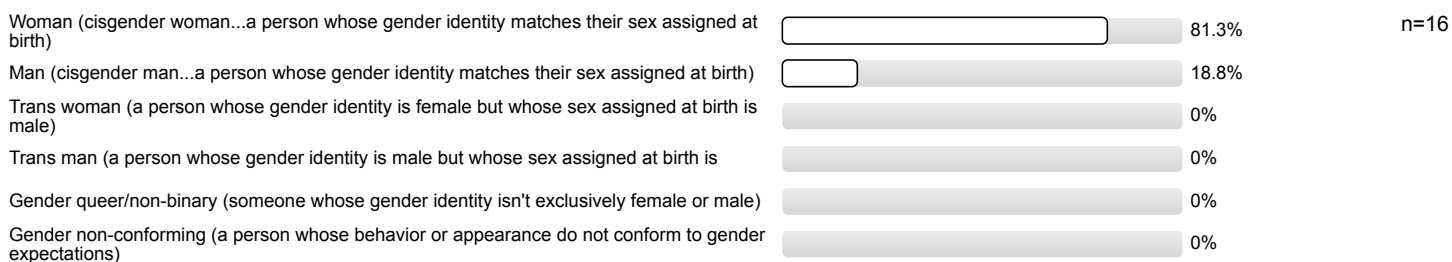

3.3) What is your sexual orientation? (MARK ALL THAT APPLY)

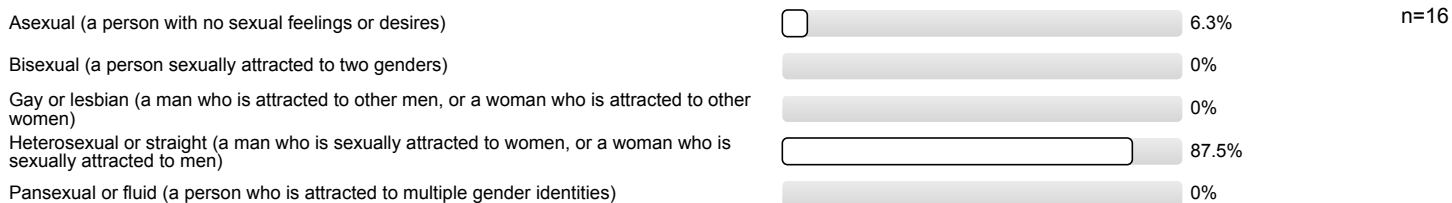

3.5) What is your age (in years)?

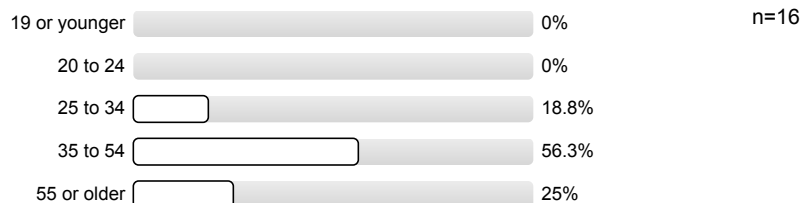

3.6) What is your race/ethnicity? (MARK ALL THAT APPLY)

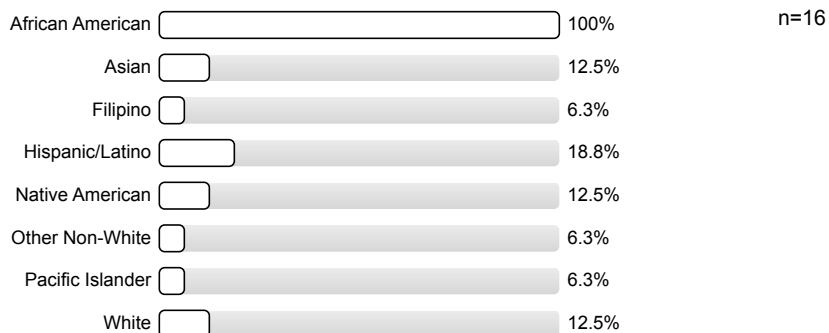

3.8) With which religions, worldviews, or spiritual backgrounds do you identify? (MARK ALL THAT APPLY)

n=16

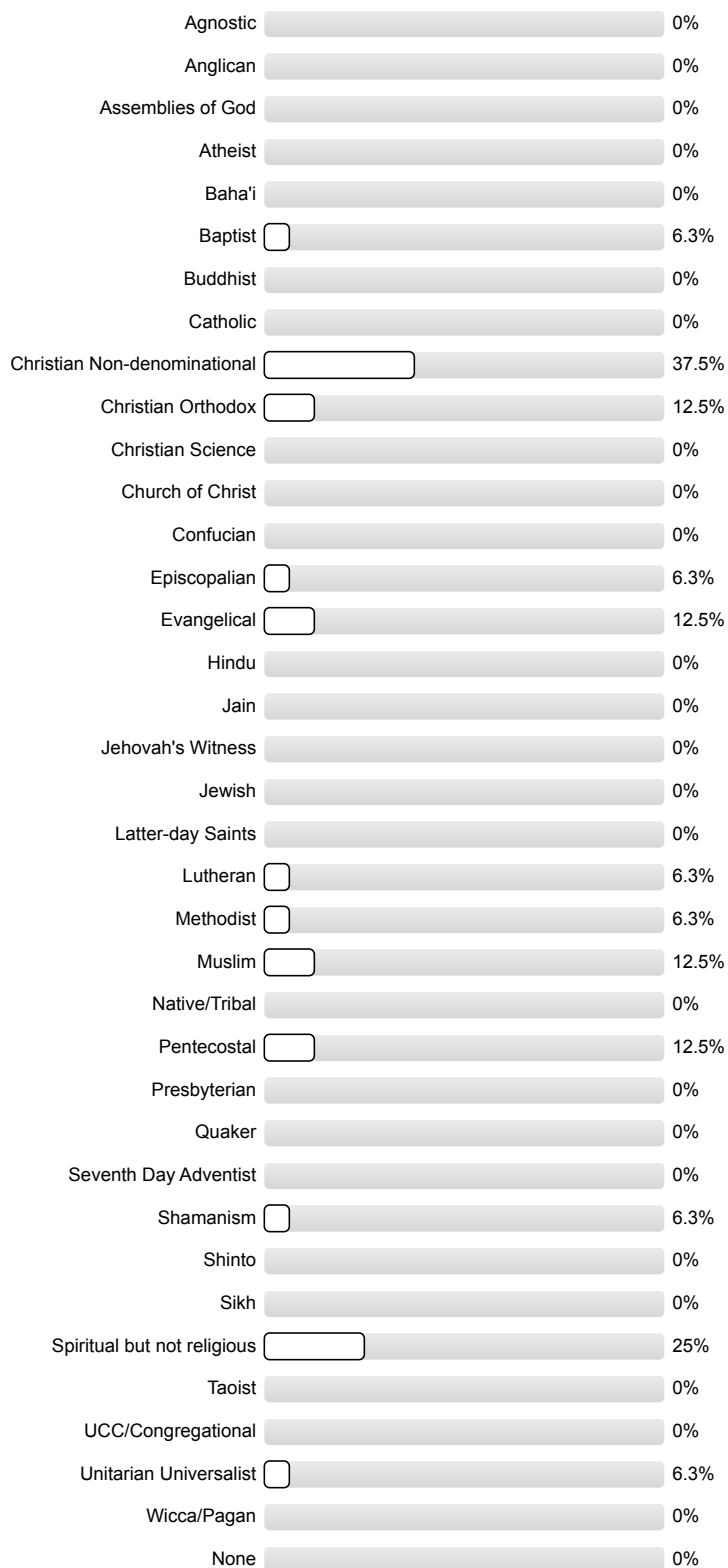

3.10) With which **one** religion, worldview or spiritual background do you **most strongly** identify? (MARK ONLY **ONE**)

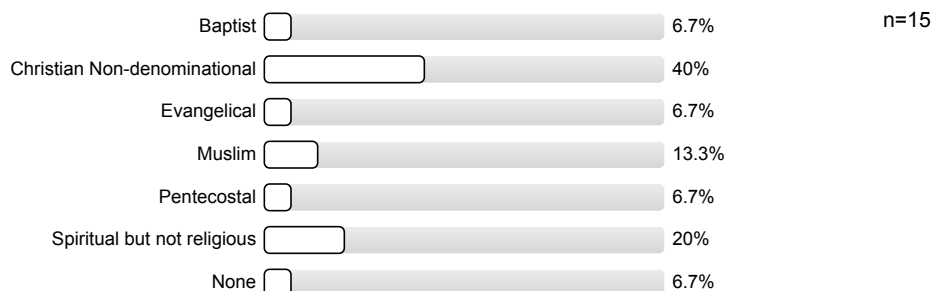

3.12) What is your highest level of education?

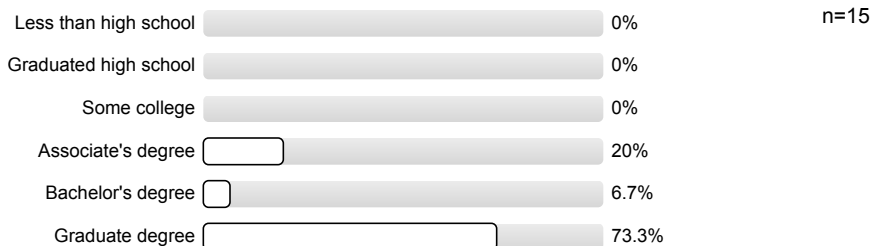

3.13) Do you have any of the following types of disabilities? (MARK ALL THAT APPLY)

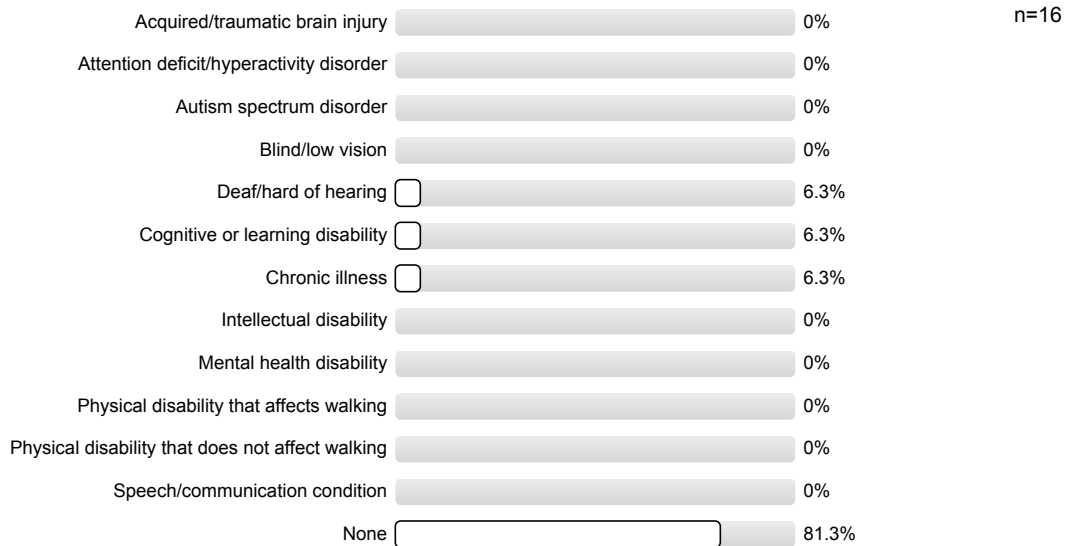

4. Institutional Effectiveness

4.1) The **teaching/learning environment is equitable and inclusive** for students at my primary ARC work location.

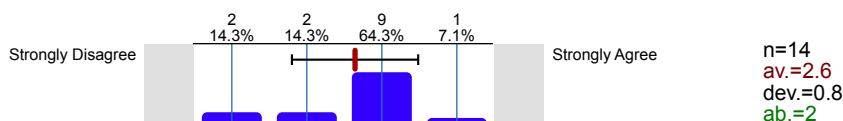

4.2) The **teaching/learning environment is safe** for students at my primary ARC work location.

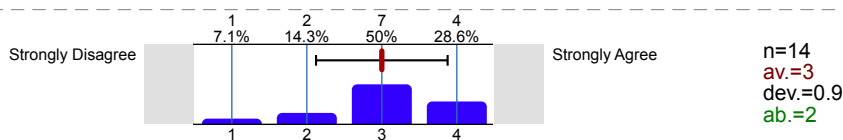

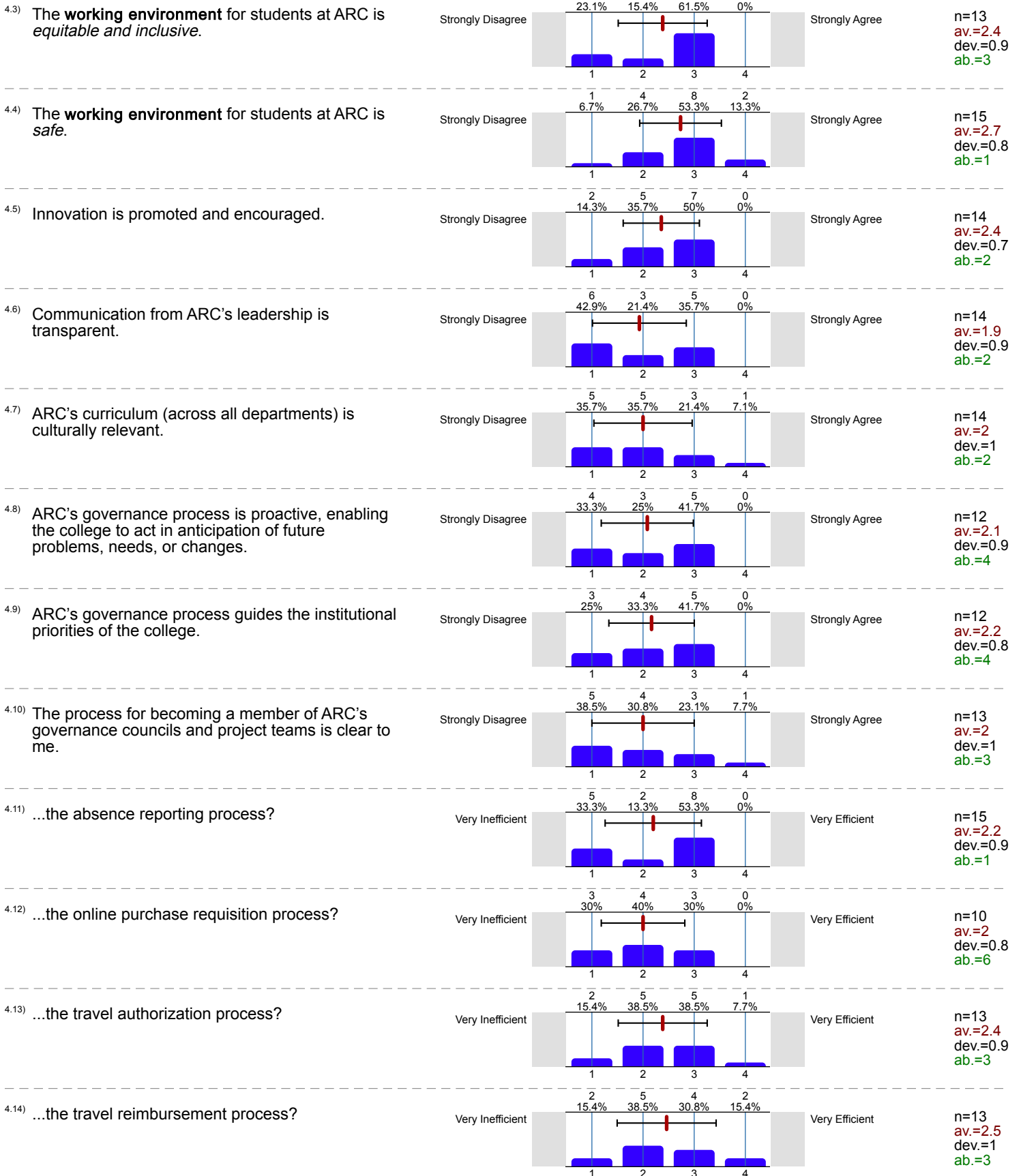

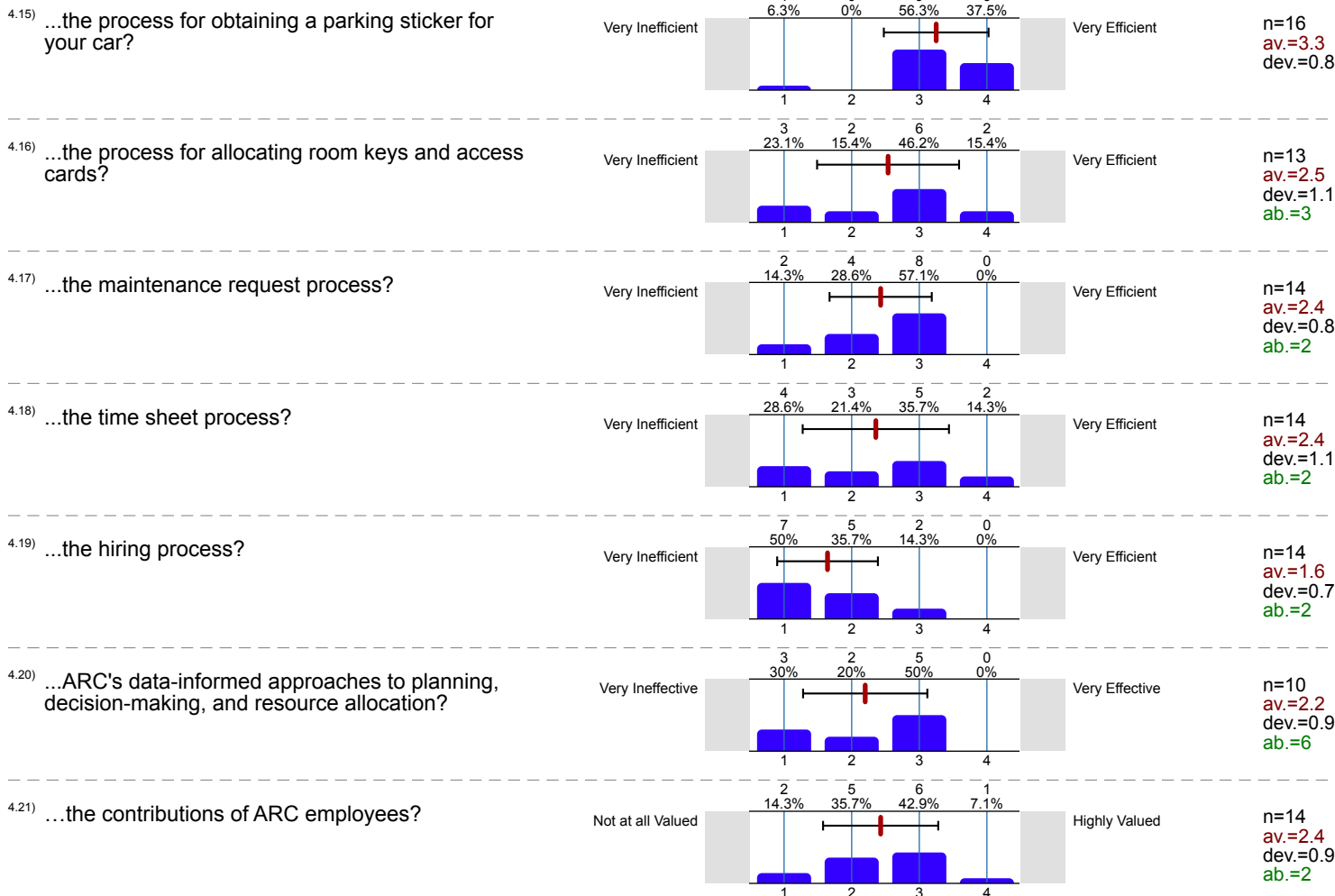

5. Student-Focus

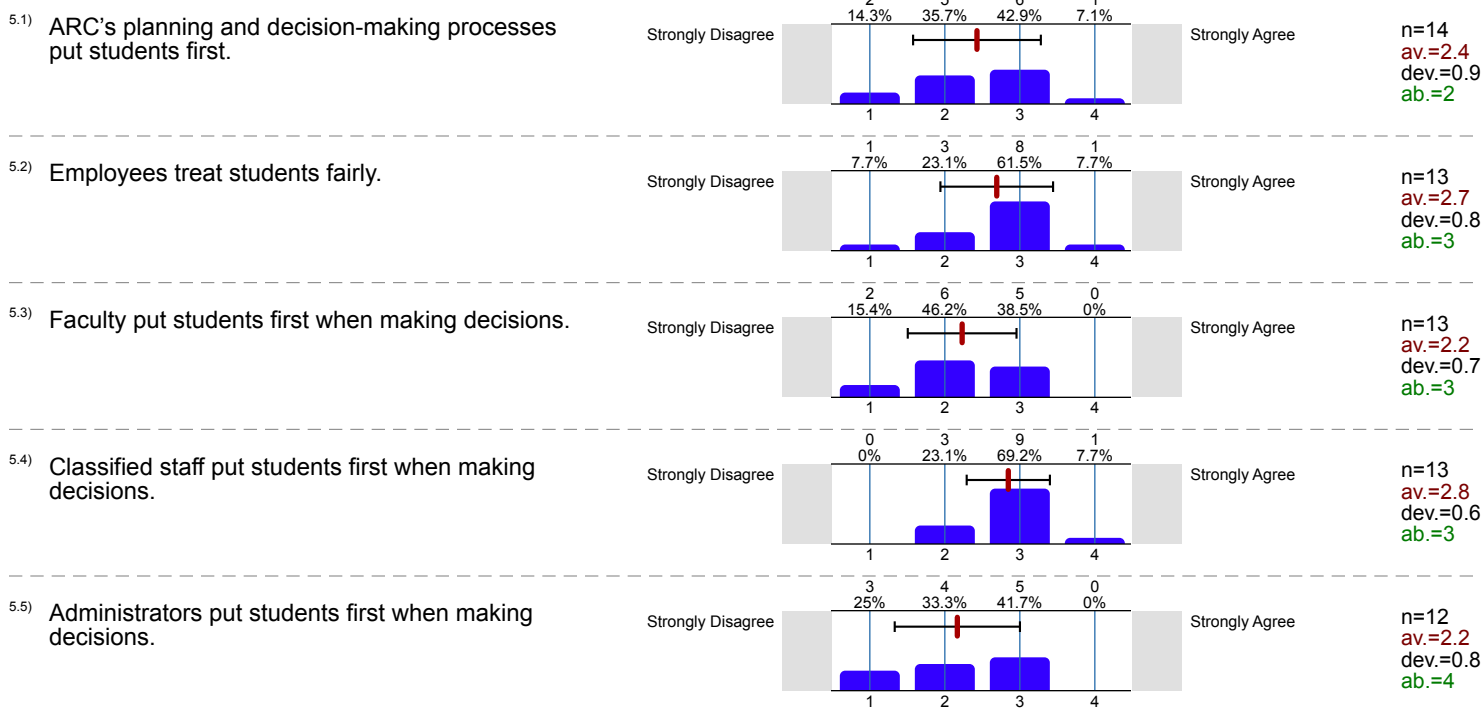

5.6) ARC provides sufficient programs and resources to foster the success of a diverse student body.

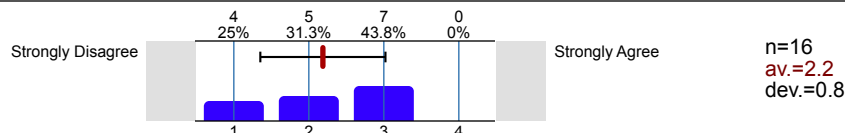

6. Teamwork

6.1) Employees work collaboratively.

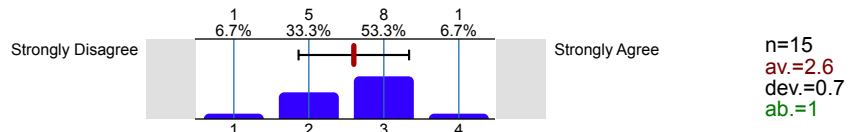

6.2) A sense of cooperation exists across employee groups at ARC.

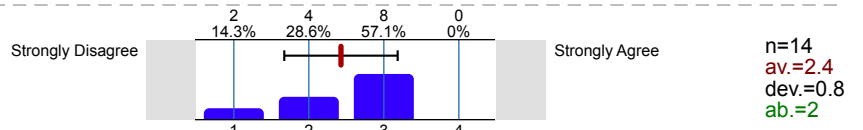

6.3) Employees go out of their way to create a welcoming climate.

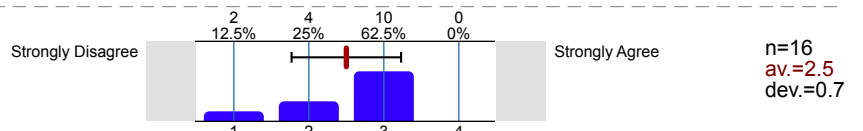

6.4) Employees treat students with respect.

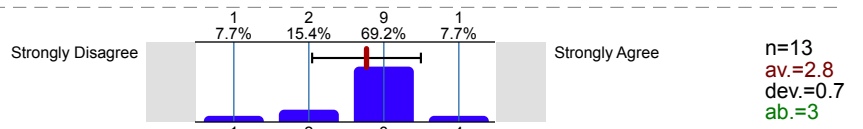

6.5) Employees treat one another in a professional and friendly manner.

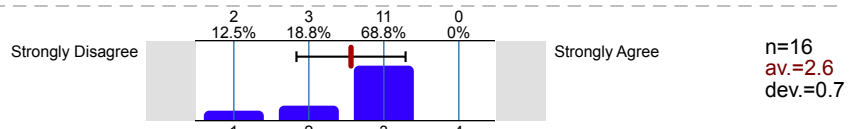

6.6) A sense of teamwork exists at ARC.

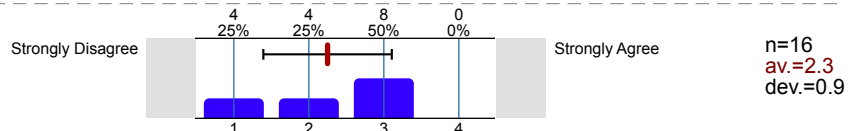

6.7) Clear expectations about my work are communicated to me.

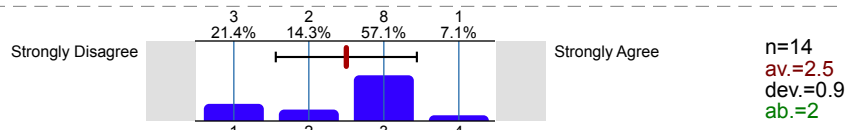

6.8) Employees at ARC use problem-solving techniques when working with others.

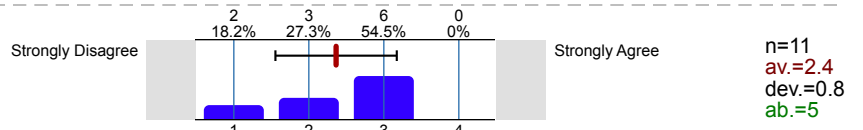

7. Job Satisfaction

7.1) Overall, I am satisfied with my job at ARC.

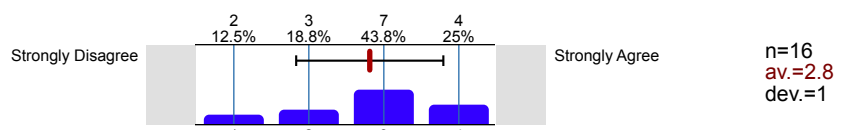

7.2) I feel pressure to accomplish too many tasks and priorities.

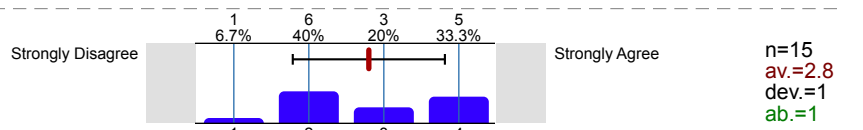

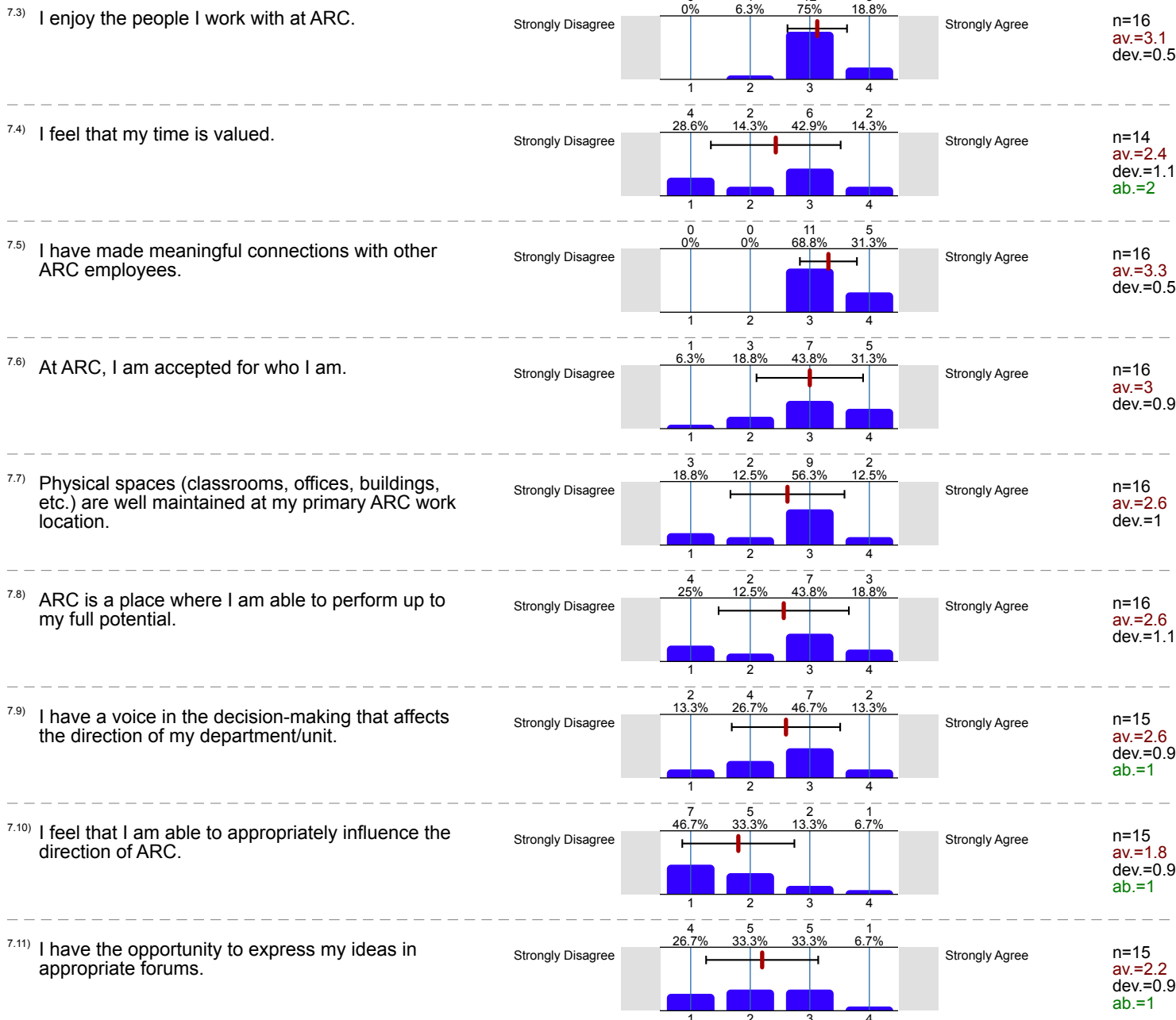

8. Faculty Specific Questions

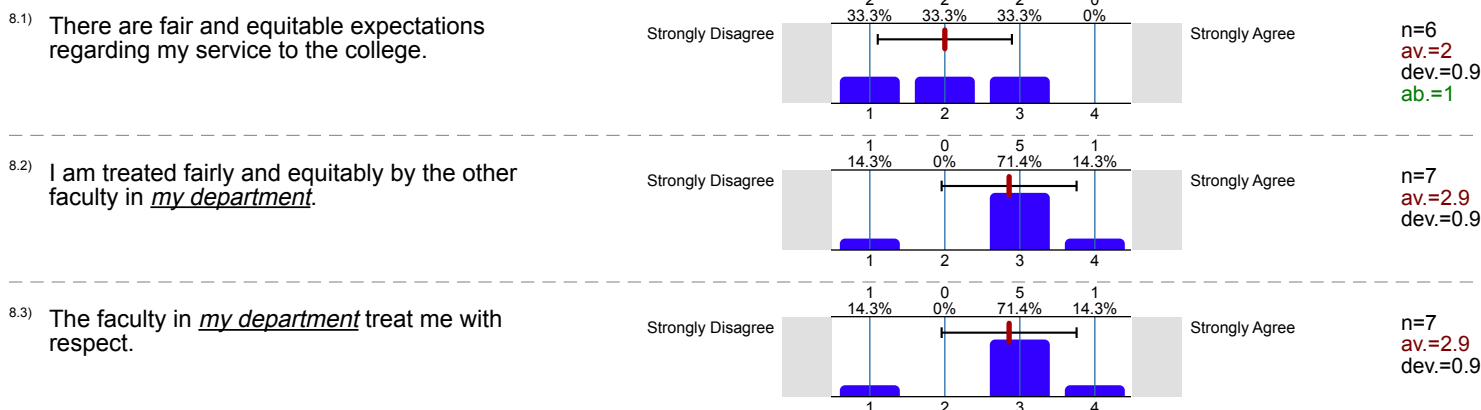



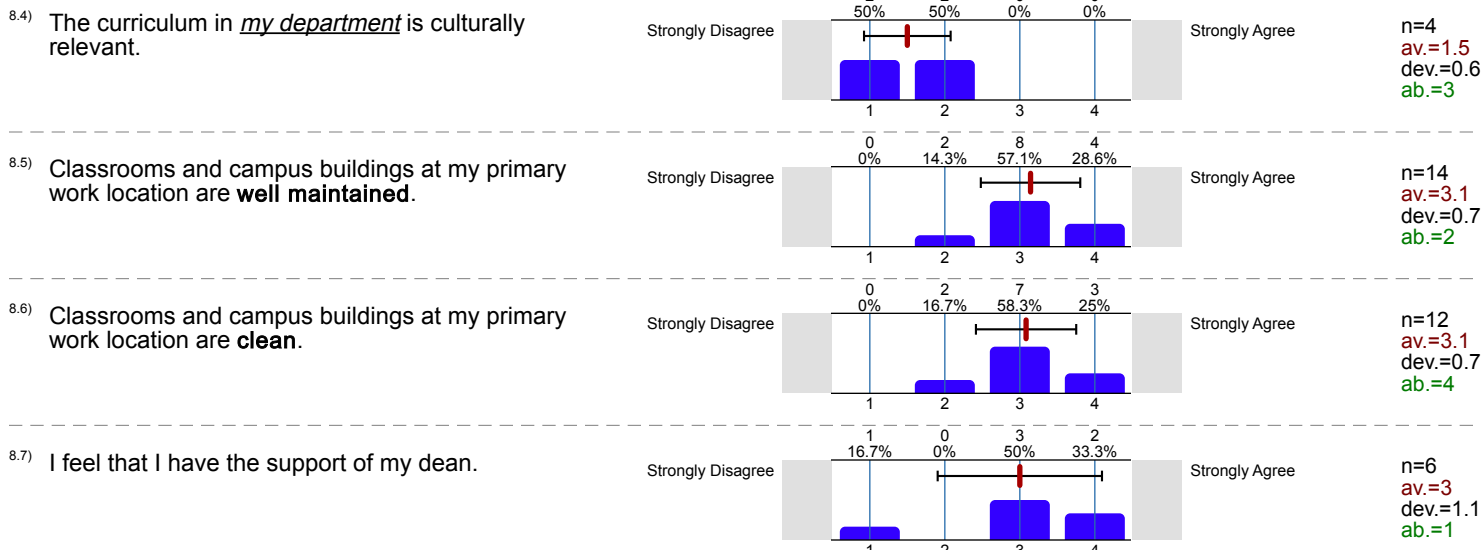

9. Professional Development

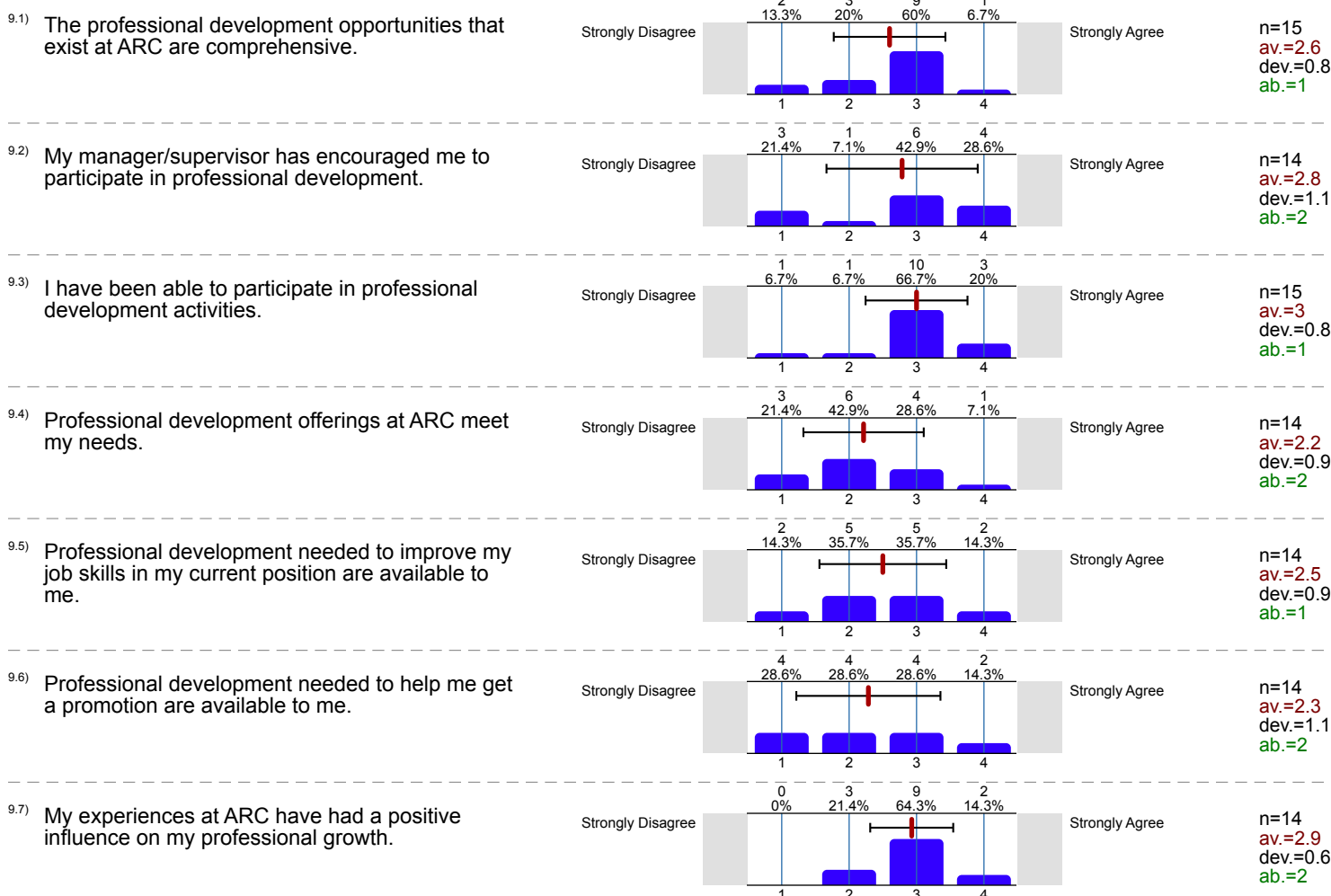

10. Equity, Inclusion, Social Justice Focus

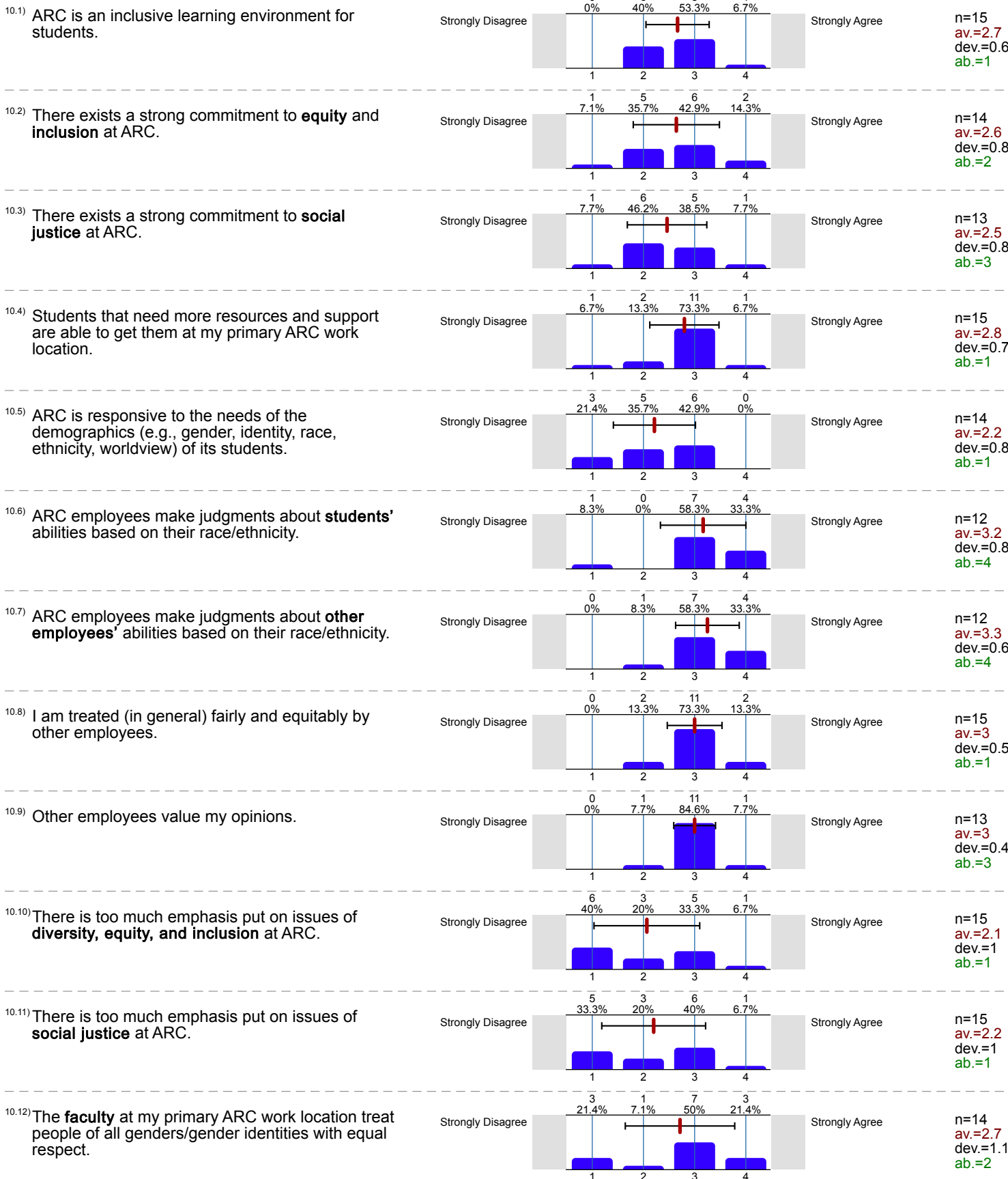



11. Each of the following questions shows a pair of adjectives that are opposite to one another. The six boxes between each pair reflect a range of responses (for example, from a 'Hostile' environment at one end of the range, to a 'Friendly' environment at the other). For each question, mark the one box between each pair of adjectives that best expresses how you feel about your primary ARC work location based on your personal experiences:

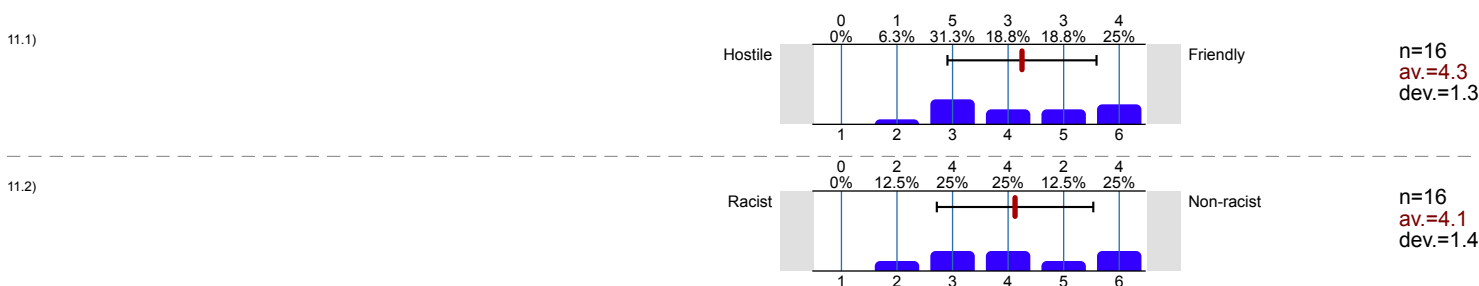

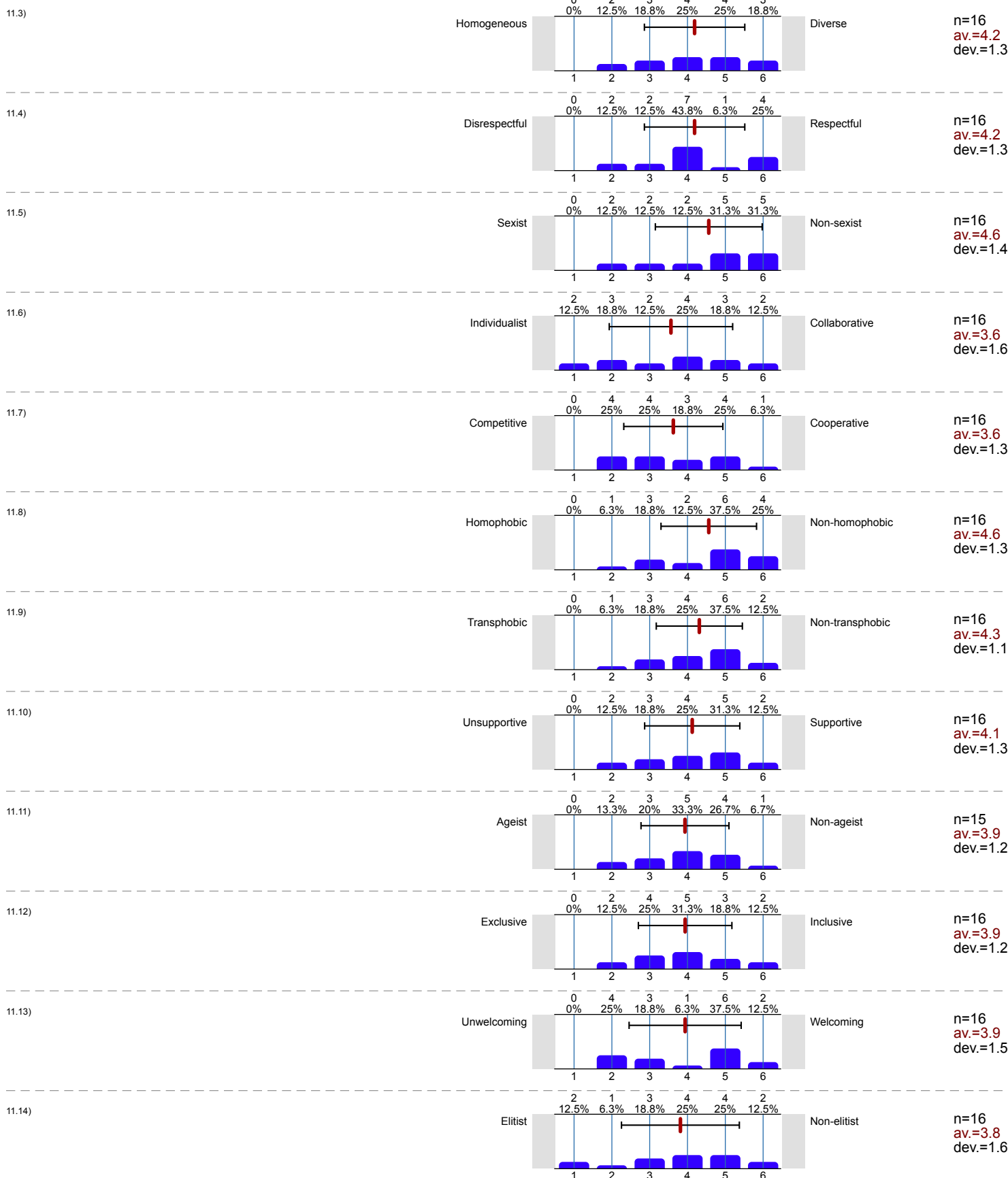

12. During the past 12 months at ***your primary ARC work location***, have you heard anyone... (MARK ALL THAT APPLY)

12.1) ...call someone homophobic names.

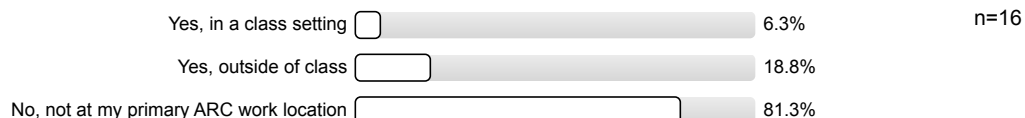

12.2) ...say sexual things to you or try to talk about sexual matters when you didn't want to.

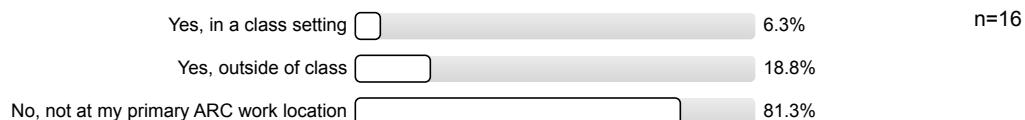

12.3) ...make crude or offensive remarks or jokes about people who identify as LGBTQ+ (lesbian, gay, bisexual, trans, queer, +).

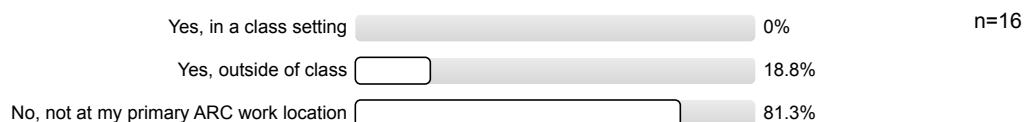

12.4) ...suggest or imply in your presence that women don't have the same intellectual abilities that men do.

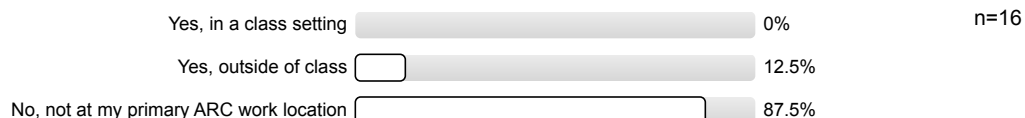

12.5) ...make inappropriate comments about your or someone else's body, appearance, or looks.

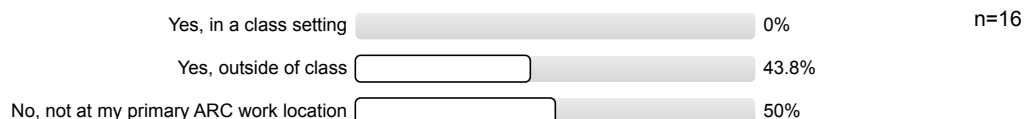

12.6) ...make sexist remarks or jokes about women.

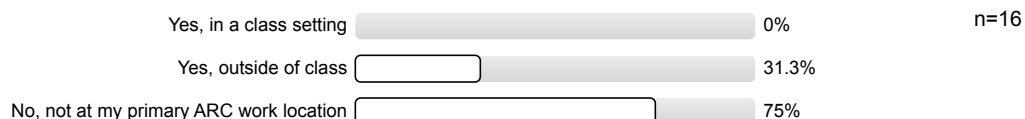

12.7) ...make sexist remarks or jokes about men.

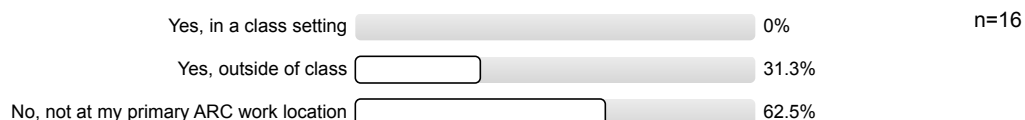

12.8) ...make negative remarks or jokes about trans women.

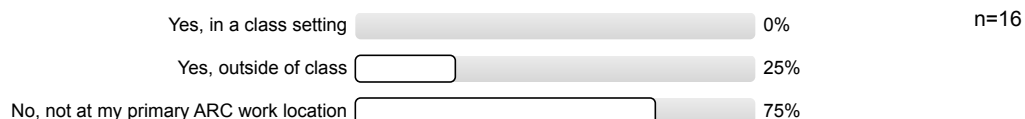

12.9) ...make negative remarks or jokes about trans men.



13. Regarding your personal **physical safety**:

13.1) During the past 12 months, have you been concerned for your **physical** safety at your primary ARC work location?

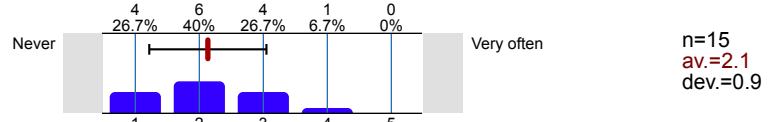

13.2) During the past 12 months, have you avoided any of the following areas at your primary ARC work location due to concerns for your **physical** safety (mark all that apply)?

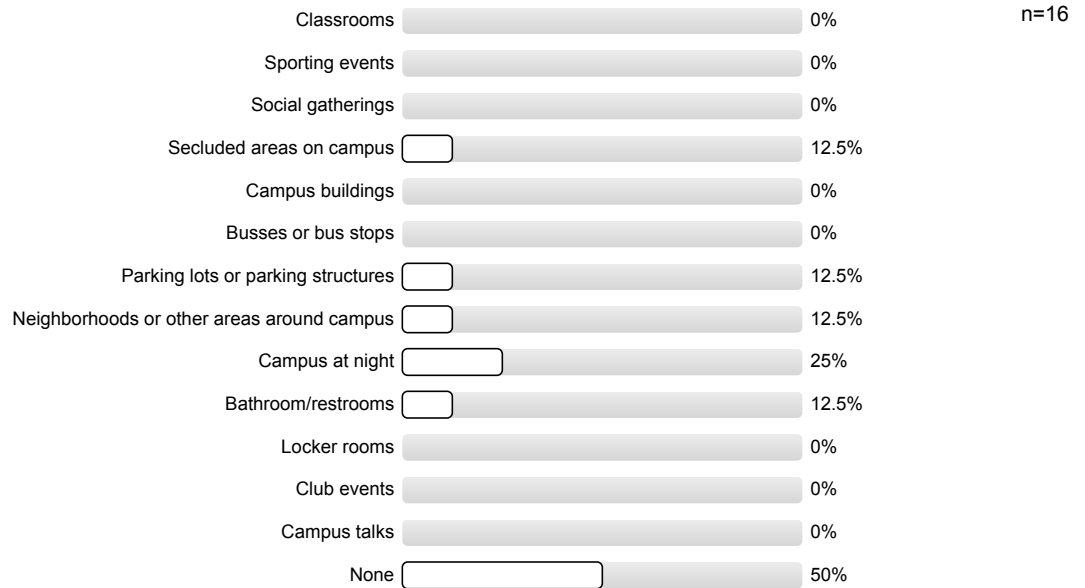

13.4) Other students

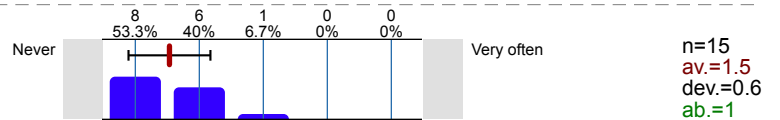

13.5) Instructors

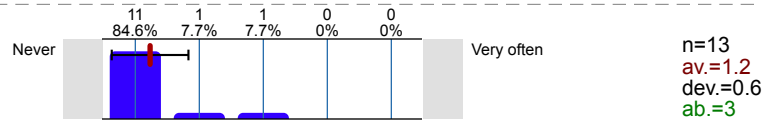

13.6) Staff

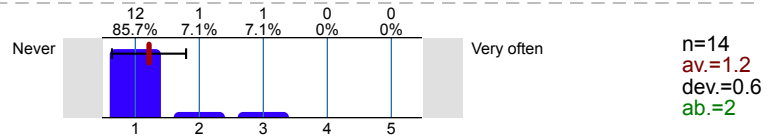

14. Regarding your **emotional safety**:

14.1) During the past 12 months, have you been concerned for your **emotional** safety at your primary ARC work location?

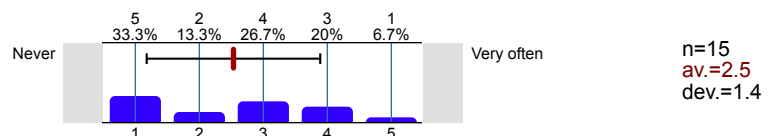

14.2) During the past 12 months, have you avoided any of the following areas at your primary ARC work location due to concerns for your **emotional** safety? (mark all that apply)

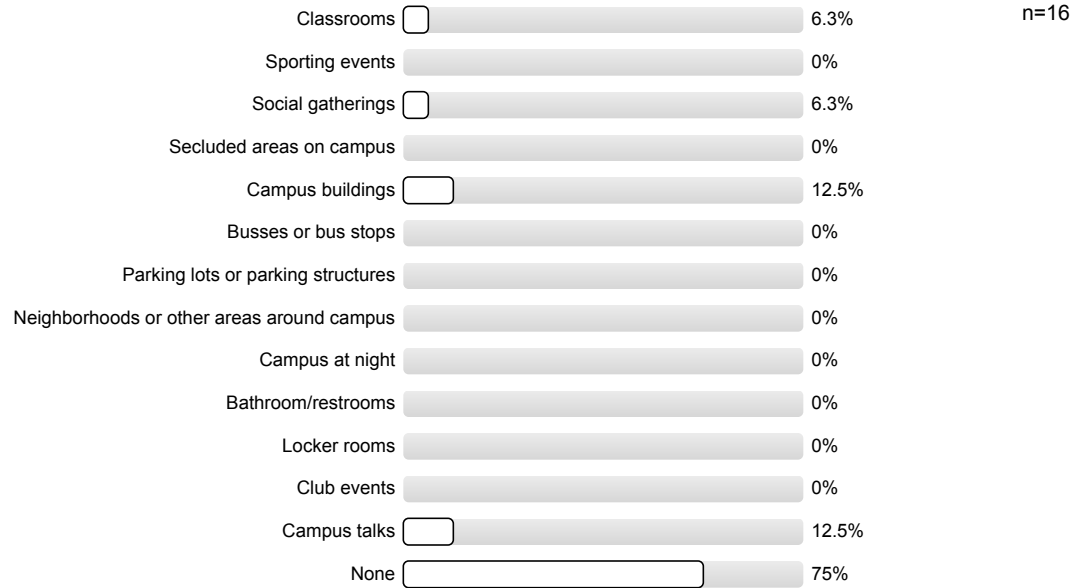

14.4) Other students

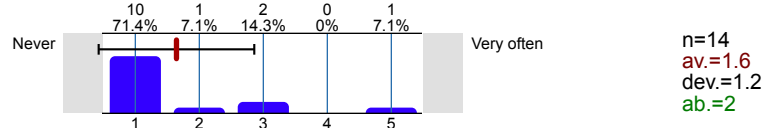

14.5) Instructors

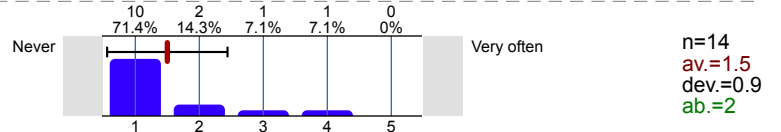

14.6) Staff

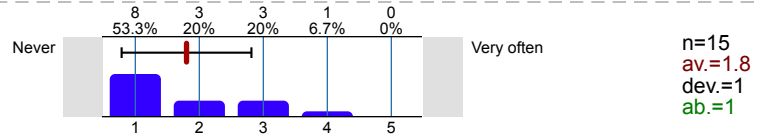

15. Regarding your primary ARC work location:

15.1) Discrimination



15.2) Threats of physical violence



15.3) Physical violence



## 15.4) Threats of emotional violence



## 15.5) Emotional violence



## 15.6) Sexual harassment

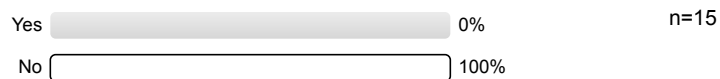

## 15.7) Other harassment



## 15.8) Sexual assault



## 15.9) Unwanted sexual advances

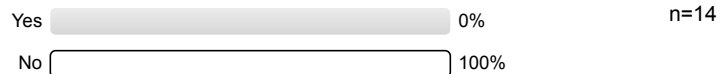

## 15.10) Verbal threats

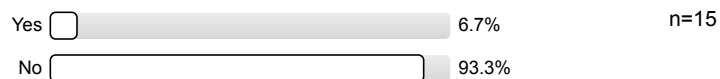

## 15.11) Discrimination



## 15.12) Threats of physical violence



## 15.13) Physical violence





15.14) Threats of emotional violence

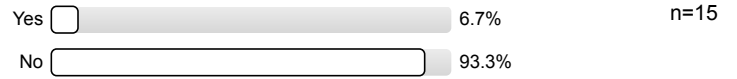

15.15) Emotional violence

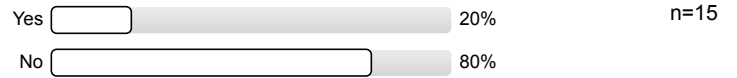

15.16) Sexual harassment

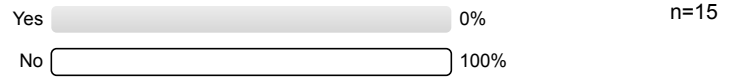

15.17) Other harassment



15.18) Sexual assault



15.19) Unwanted sexual advances

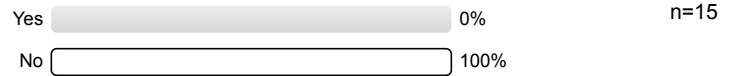

15.20) Verbal threats



16. During the past 12 months, have you experienced microaggressions at your primary ARC work location with regard to your...

16.1) ...gender/gender identity

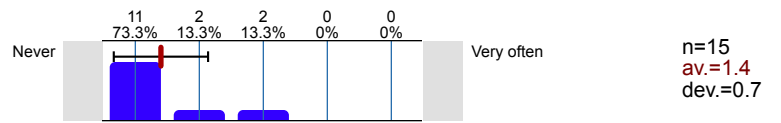

16.2) ...sexual orientation

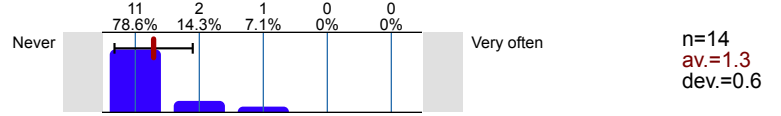

16.3) ...racial, ethnic, or cultural identity

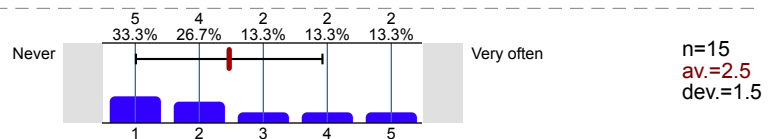

17. During the past 12 months, do you feel YOU have been mistreated *by students* at your primary ARC work location because of your:

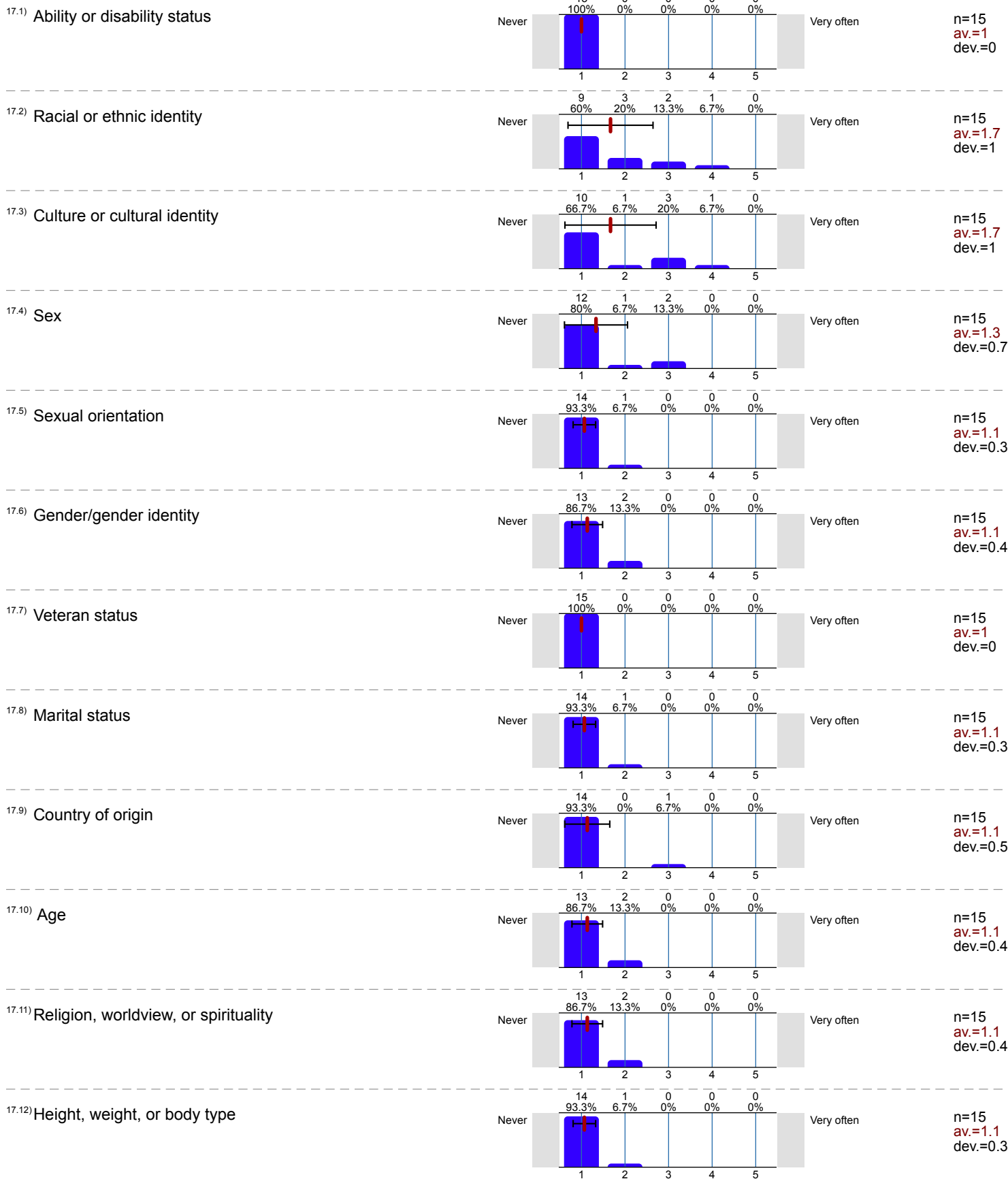



18. During the past 12 months, do you feel **YOU have** been mistreated *by faculty* at your primary ARC work location because of your:





19. During the past 12 months, do you feel **YOU** have been mistreated *by classified staff* at your primary ARC work location because of your:

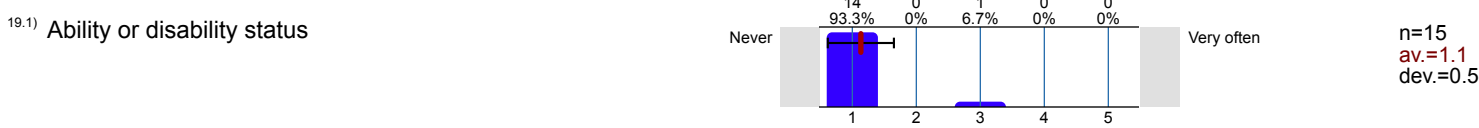



20. During the past 12 months, do you feel **YOU** have been mistreated *by managers (administrators, supervisors)* at your primary ARC work location because of your:



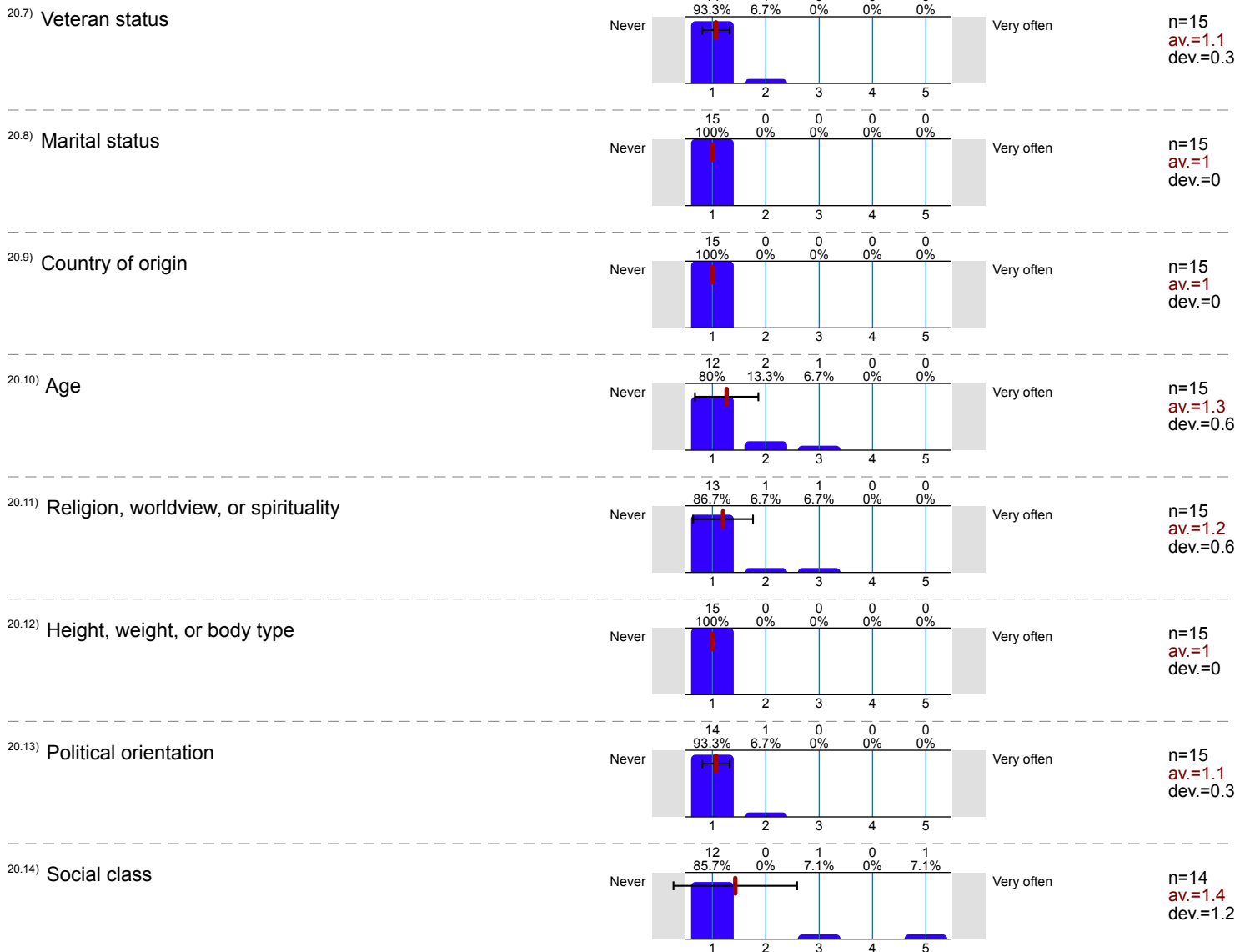

21. During the past 12 months, have you seen faculty, classified staff, or managers mistreat *students* at your primary ARC work location because of their:

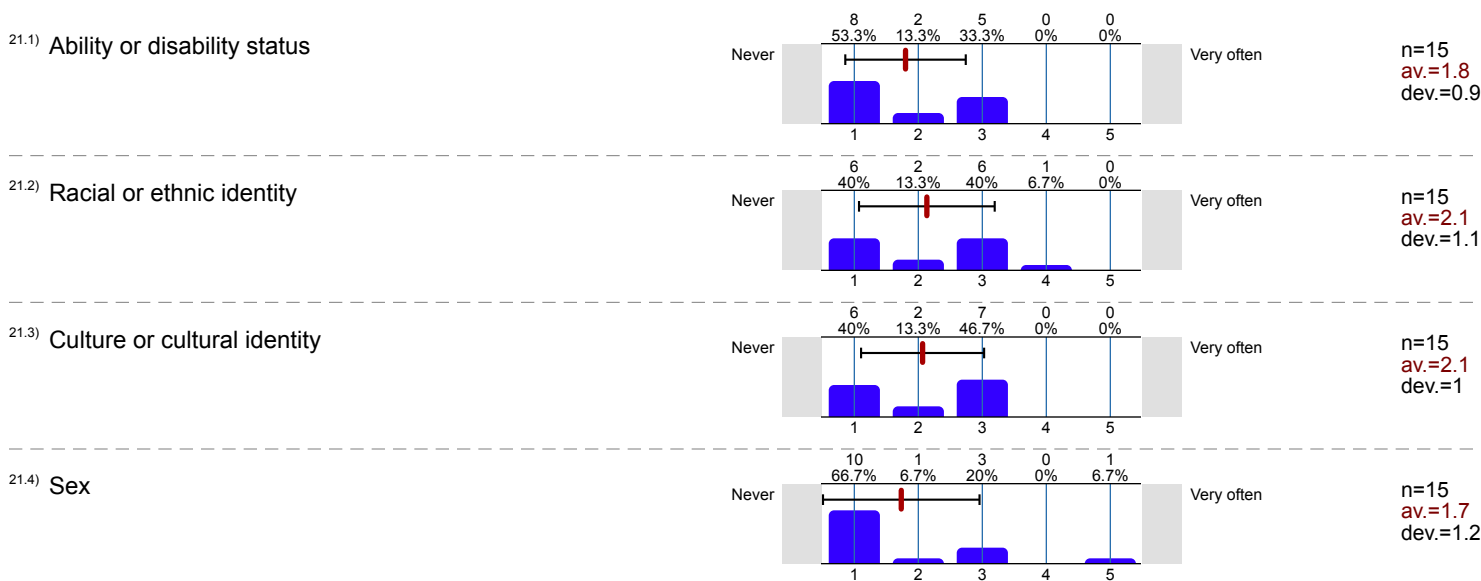

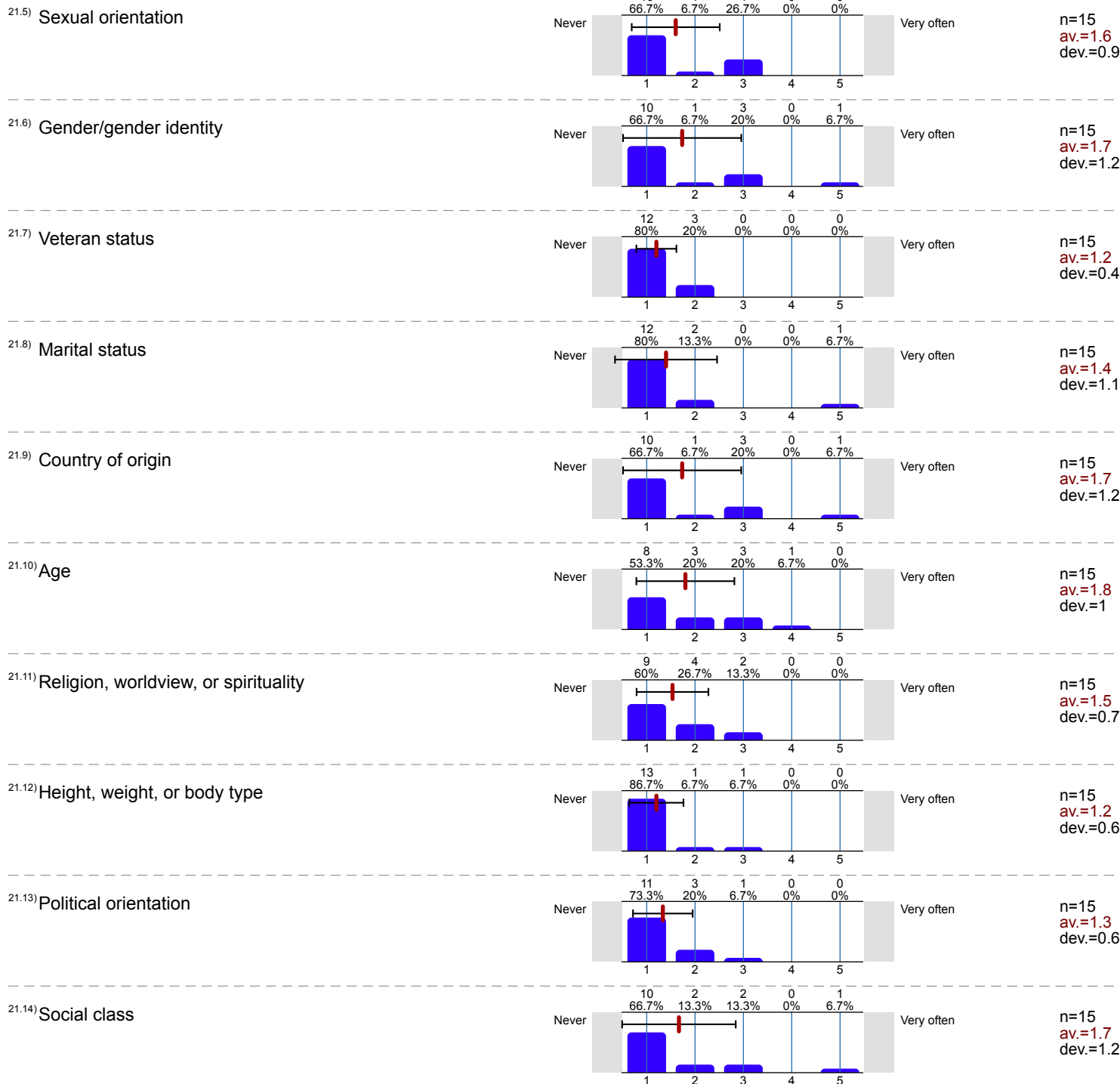

22. During the past 12 months, have you seen faculty, classified staff, or managers mistreat other faculty, classified staff, or managers at your primary ARC work location because of their:

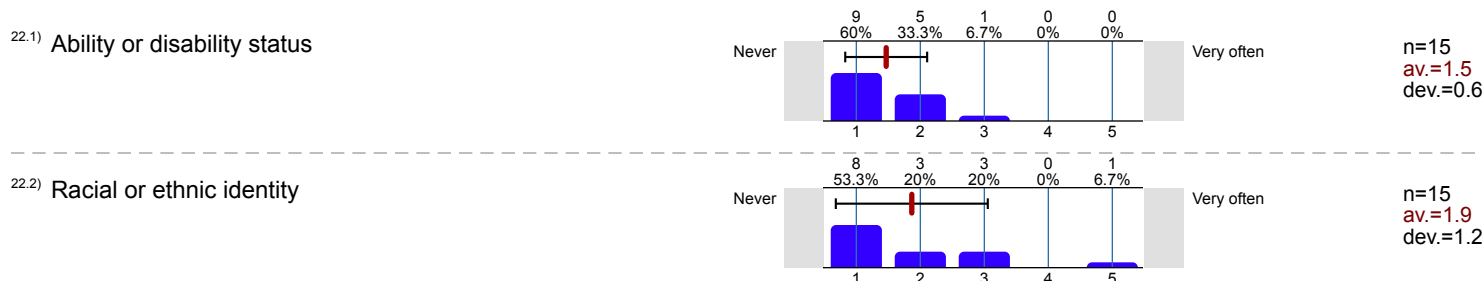

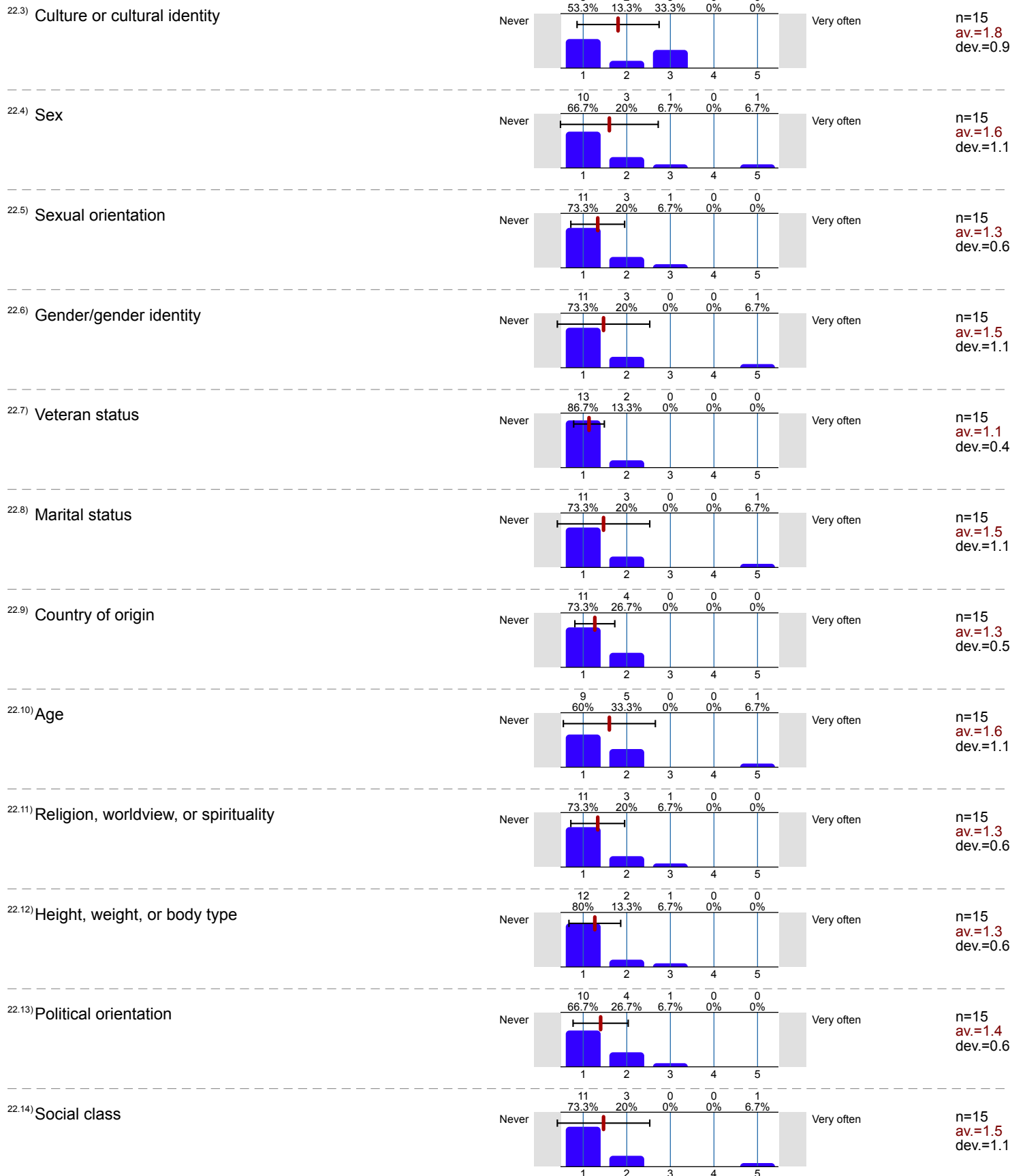



23. During the past 12 months at your primary ARC work location, how often have you interacted in a meaningful way with people...

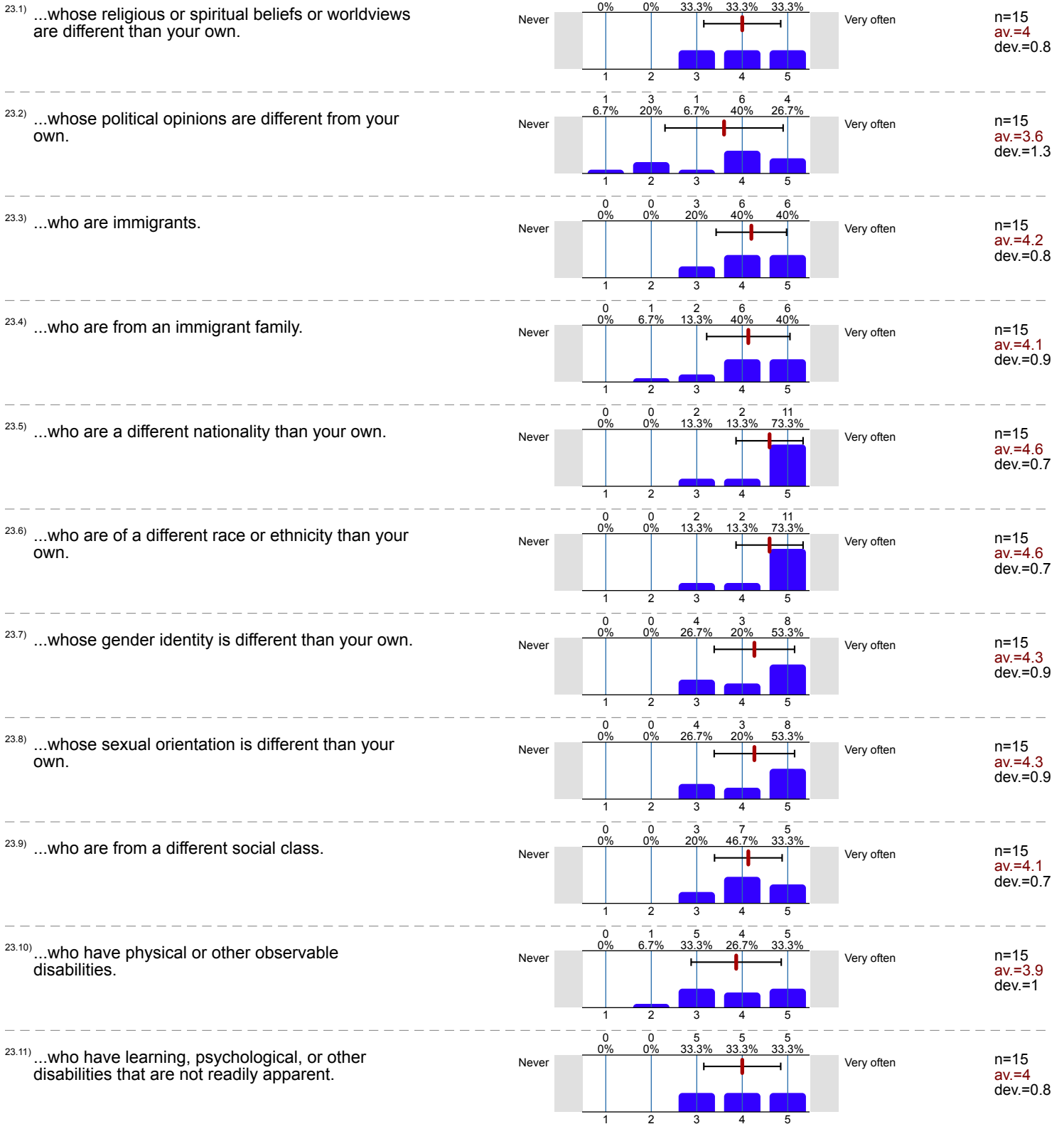

24. Overall campus climate at your primary ARC work location:

24.1) During the past 12 months, how satisfied or dissatisfied are you with the overall campus climate/environment that you have experienced at your primary ARC work location?

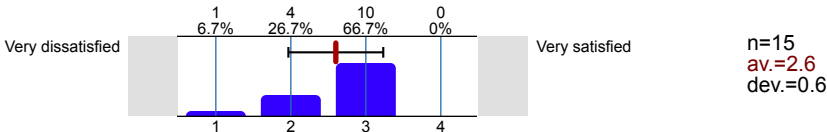

## Comments Report

### 3. Demographics

3.7) Aside from how you responded above, please list in the text box below all of the specific races, ethnicities, tribes and cultures with which you **strongly** identify (for example, Jamaican, Columbian, Punjabi, Cherokee, Armenian).

- African American, Mexican, Japanese
- Hebrew, Israelite
- Somali
- Somalia

3.9) Other religions, worldviews, or spiritual backgrounds:

- Hebrew

3.11) Other religion, worldview, or spiritual background:

- Hebrew

### 13. Regarding your personal physical safety:

13.3) Other areas you have avoided at your primary ARC work location due to concerns for your **physical** safety:

- I make sure to walk outside with other's at night. The construction makes it difficult to easily access parking lots at night.
- n/a
- raef hall women's bathrooms are set up in a way that makes them feel unsafe inside.

### 14. Regarding your emotional safety:

14.3) Other areas you have avoided at your primary ARC work location due to concern for your **emotional** safety:

- Work space
- n/a

14.7) Other:

- Administrators
- administrators
- n/a

20. During the past 12 months, do you feel **YOU have** been mistreated by managers (administrators, supervisors) at your primary ARC work location because of your:

20.15) Please describe any other ways you feel you've been mistreated by students, faculty, classified staff, or managers (administrators, supervisors) at your primary ARC work location (for example, because of your accent, hairstyle, clothing, income, etc.)

- I am often mistaken for several other african american female employees on campus. I am often told that I do not look anything like I sound.
- Not me, personally, however, some memes were found on a shared drive that were put there by a classified person in our area, which fall under discrimination based on race, ethnicity, gender and political party that were disturbing. I was told that it was free speech, and that

the only thing the person could be confronted about was their use of district assets to search and store the offensive memes.